



Esso Australia Pty Ltd

913713 001

WELL COMPLETION REPORT
BEARDIE-1
VOLUME 1
BASIC DATA
FEBRUARY 2003

PAGE 1 OF 117





Esso Australia Pty Ltd

913713 002

WELL COMPLETION REPORT
BEARDIE-1
VOLUME 1
BASIC DATA
FEBRUARY 2003

11 FEB 2003



WELL COMPLETION REPORT

BEARDIE-1

**VOLUME 1
BASIC DATA**

**GIPPSLAND BASIN
VICTORIA**

ESSO AUSTRALIA PTY LTD

*Compiled by, Bruce Menzel, Sheryl Sazenis
January 2003*

WELL COMPLETION RPEORT BEARDIE-1

**VOLUME 1:
BASIC DATA**

CONTENTS

1. WELL DATA RECORD
2. OPERATIONS SUMMARY
3. CASING DATA
4. CEMENTING DATA
5. SAMPLES, SIDEWALL CORES
6. WIRELINE LOGS AND SURVEYS
7. SUMMARY OF FORMATION TEST PROGRAMME
8. TEMPERATURE RECORD
9. LWD/MWD RUN SUMMARY

FIGURES

1. LOCALITY MAP
2. WELL PROGRESS CURVE
3. WELL BORE SCHEMATIC
4. ABANDONMENT SCHEMATIC
5. HORNER TEMPERATURE PLOT

APPENDICIES

- 1 LITHOLOGICAL DESCRIPTIONS
2. SIDEWALL CORE DESCRIPTIONS
3. MDT RESULTS
4. MUDLOGGING REPORT
5. VSP REPORT
6. PETROGRAPHY

<p style="text-align: center;">WELL COMPLETION RPEORT BEARDIE-1</p>

VOLUME 1:
BASIC DATA (cont'd)

ENCLOSURES

1. MUD LOG
2. PRESSURE LOG
3. DRILLING LOG
4. GAS RATIO LOG

I. WELL DATA RECORD

LOCATION : Latitude : 38° 15' 16.214" S
 Longitude : 147° 48' 24.643" E
 X= 570,594.15 East
 Y= 5,765,624.16 North

 Map Projection: UTM Zone 55 / AMG Zone 55
 Central Meridian 147° East
 Geographical Location: Victoria,Australia.

FIELD : Gippsland Basin, Victoria
 PERMIT : Gippsland Basin, Vic / L2
 ELEVATION : -76.2m MD
 WATER DEPTH : 51.2m MD
 TOTAL DEPTH : 1905.0m MD(Driller)1909.5m
 MD(Logger)
 REASONS FOR PLUGGING BACK : Plugged and abandoned
 MOVE IN : 24th July 2002
 SPUDDED : 26th July 2002
 REACHED TD : 3rd August 2002
 RIG RELEASED : 10th August 2002
 OPERATOR : Esso Australia Resources Pty Ltd.
 PERMITTEE OR LICENCEE : BHP Billiton Petroleum (Bass Strait) Pty
 Ltd and Esso Australia Resources Pty
 Ltd
 ESSO INTEREST : 50 %
 OTHER INTEREST : BHPB 50%
 CONTRACTOR : Diamond Offshore General Company
 RIG NAME : Ocean Bounty
 EQUIPMENT TYPE : Semi-Submersible
 TOTAL RIG DAYS : 18
 DRILLING AFE NO : L0501B003
 TYPE COMPLETION : Plugged and Abandoned
 WELL CLASSIFICATION : Wildcat

II. OPERATIONS SUMMARY

1. MOVING/PLUG AND ABANDON

The Ocean Bounty was released by OMV to Esso and simultaneously commenced its tow of 62 nautical miles to the Beardie-1 location at 17:00 hrs on the 25th July 2002. The Ocean Bounty arrived at location at 0030 hrs on the 26th of July 2002, and commenced running anchors.

2. DRILLING OPERATIONS

36" Hole/ 30" Casing.

The 26" / 36" hole section was drilled to 122.54 metres.

The 36" hole was drilled riserless using a 26" Security S3S J4 bit (new bit run1) with a 36" hole-opener. The sea floor was tagged (firm) at 76.23m MDRT, Beardie-1 was spudded at 1700 hrs on the 26th July 2002. The 36" hole section was drilled with seawater, 50bbl hi-vis prehydrated gel (PHG) sweeps were pumped every 15 metres. At section TD (122.54m) the hole was swept clean with 100 bbl's guar pill and then displaced with 400 bbl's hi-vis mud. Anderdrift hole surveys were run during this phase. A short trip to 84m was completed and the tools run back to bottom. No fill was recorded and a 400 bbl hi-vis pill was spotted on bottom prior to pulling out of the hole to run 30" casing.

30" casing run to 122m and cemented.

After a JSA meeting, four joints of 30", X52, ST-2 thread casing were made up and landed off the PGB on moon-pool beams. The cement stinger and running tools were engaged to the 30" casing and the casing and PGB run into the hole on HWDP. The casing was stabbed into the hole with the assistance of the ROV and by moving the rig. The 30" casing was landed at 122m with no hole problems. After moving the rig to decrease the PGB bulls eye to ¼ degrees, a pre-flush pill of 20 bbls of 8.5 ppg seawater with fluorozone was pumped followed by a lead slurry comprised of 1228 sacks of G class cement with 1% Calcium chloride mixed to a 256 bbl, 15.9 ppg slurry. Displacement of this slurry was completed by pumping 18 bbls of 8.5 ppg seawater. The plug was not bumped. A similar volume of cement was returned to the seabed. As the float shoe did not hold, pressure was held on the landing string. The running tool was released and the drilling assembly pulled out of the hole and broken down. After picking up the 17.5" drill string, tools were run in the hole to the top of the 30" housing and stabbed into the housing and run to the top of the cement.

17-1/2" Hole was drilled from 123.5m to 863m.

Cement was tagged at 117m and the cement and shoe were drilled and new hole drilled riser less to 863m with a Hycalog DS34 HF+GN fixed cutter (PDC) bit (bit run 2), made up to a packed drilling assembly. Returns were monitored with the ROV. Surveys were run with an Anderdrift tool. The hole was swept

II. OPERATIONS SUMMARY (cont'd)

with 100 bbls of high viscosity pre hydrated gel mud and an 800 bbl pill spotted at bottom. After completing a wiper trip to 323m, the tools were run back to bottom and no fill was encountered. After pumping 300 bbls of sea water a Scientific Drilling gyro was dropped and followed by 12 ppg mud at a slow pump rate. The drill string was pulled out of the hole and 110 bbl 12 ppg pill spotted on bottom. The well head was jettied as tripping continued and after retrieving the gyro survey, the bit and two stabilizers were laid down. After completing a JSA, tools were rigged up to run 13 3/8", K55 thread, 68 ppf casing was run. PGB bullseye was noted as 1/2 degree forward port. The final survey at 852.7m indicated an inclination of 0.56 degrees and an azimuth of 173.86 degrees.

13-3/8" casing run to 873m and cemented.

The 13 3/8" casing string consisted of 1 joint 20", x56, H4 casing at the top followed by one joint of welded L80 followed by 63 joints of buttress threaded K55, 68 ppf, at the bottom of the string. The casing was filled at each joint and run into the hole to 873m. Halliburton pressure tested their lines prior to pumping a pre flush of 50 barrels of 8.5 ppg seawater followed by a lead slurry of 1335 sacks class G cement mixed with Econolite additive (526 barrels of 12.5 ppg SG slurry). This was followed by a tail slurry comprised of 726 sacks Class G cement mixed with fresh water (150 barrels of 15.8 ppg slurry). A post-flush pill of 10 barrels of drill water was pumped and the cement slurry was displaced with 369 barrels of 8.5 ppg seawater. The plug was not bumped after full displacement plus half the shoe track volume was pumped. Pressure was held for 2 minutes and then bled off and the floats held. The 18 3/4" running tool was released and pulled out of the hole and laid down. After servicing the cement head it was laid down and tools were rigged up to run the marine riser after completion of a JSA pertinent to the job at hand.

12 1/4" Hole was drilled from 863m to 1905m

The BOP's were nipped up and functioned tested and the BOP/riser assembly run. Choke and kill lines were pressure tested on the riser double, the slip joint and landing joint were picked up and the goose necks fitted to the slip joint. Lines were then pressure tested and rucker lines assembled and fitted. The BOP's were landed and latched with confirmation supplied by 50K pounds overpull. The casing and wellhead connector were pressure tested against the blind rams; the slip joint stroked out, diverter installed and riser handling equipment rigged down.

II. OPERATIONS SUMMARY (cont'd)

The MWD equipment was rigged up, serviced and laid out. After servicing the top drive, the hang off tool was picked up and racked back. After a JSA, the MWD tool was made up and tested. The assembly was run in the hole to the top of the cement at 820m. The Lower marine Riser Package was pressure tested against the casing and held. After function testing the BOP yellow and blue pods, drilling of the cement commenced and shoe track drilled. At this point, the hole was displaced with pre-hydrated polyacrylamide mud and 3m of new formation were drilled. After circulating bottoms up and displacing the choke and kill lines, a pressure integrity test was carried out resulting in 14.7 ppg equivalent mud weight being achieved prior to formation breakdown.

The 12 1/4" hole section was drilled with 2 bit runs. MWD was used for direction control with the bonus of GR and resistivity log (ARC) to 1579m when it was removed during a bit trip. From 1579m to TD, gyro surveys were taken in addition to MWD surveying. KCL/ PHPA/Polymer/Glycol mud was used to drill the 12 1/4" hole section. The mud was weighted at 9.8 ppg. One Formation Integrity Test was conducted while drilling the 12 1/4" hole. It was conducted at 852m, 3m out of the 13 3/8" shoe. This test was conducted after displacing the hole with 8.9 KCL/ PHPA mud. This test recorded a formation break down pressure pressure of 838 psi for an EMW of 14.7ppg.

Summary of Bit Runs

Bit Run (3) 885m - 1579m 12 1/4" Hycalog DSX195DGNUW

Bit 3 was run into the hole following the 13 3/8" casing run. The bit tagged the top of the cement at 820m and drilled the float and shoe plus 3 metres of new formation to 852.1m with seawater. Bit 3 drilled a total of 716m in 28.1 hours on bottom with an average ROP of 25.5 m/hr, the bit TD was 1759m. Hard streaks were drilled at 1339m, 1347m. A precautionary flow check was performed on entering the top of the Latrobe (TOL 1182m) and further flow checks were completed at 1,195m and 1,287m and 1,579m before pulling out of the hole. After pumping a slug, the string was pulled from the hole; minor overpull of 20 Kips being experienced at 1,282m and 1,098m. The bit was pulled because it was unable to make hole in hard siliceous and pyritic sandstone. The bit grading was 5-8-LT-N-X-1-RO-PR. The hole built to 0.9° inclination through this section. The LWD tools were laid out as the ARC tool had stopped transmitting data to surface however the memory data was found to be good. The MWD tool functioned normally throughout.

Bit Run (4) 1759m - 1905m, 12 1/4" Reed, EHP51HPRDH.

The aim of bit run 4 was to drill the hard pyritic and siliceous, dolomitized sandstones which had stopped the previous bit. After making up the BHA and drill string together with the MWD and CDR resistivity tool, the tool was tested OK and the rest of the drill string including ten 8 1/2" drill collars was made up

II. OPERATIONS SUMMARY (cont'd)

After tripping in the hole to the casing shoe, the top drive was serviced and trip continued to 1,537m. As a precaution the bit was washed and reamed to 1,579m with a trip gas indication of 0.18%. Drilling then continued without incident to a total depth of 1,905m. Bit 4 was graded 3-4-WT-A-E-2-NO-TD. Hole inclination remained effectively unchanged through this section with 0.98° inclination being measured at 1869m and 0.98° projected to 1905m. Bit 4 drilled a total of 326m in 34.4 hours on bottom with an average ROP of 9.5 m/hr.

Suite 1 of wire line log run

Run 1 DUAL AXIS DENSITY-PEX-HALS- LEHQT
 Run 2 FMI-DSI-HNGS-GR-LEHQT
 Run 3 MDT-GR-LEHQT
 Run 4 DUAL CSAT-VSP
 Run 5 CST-GR-LEHQT
 Run 6 DSI in Casing to sea floor

III. CASING DATA

Type	Size (inches)	Weight (ppf)	Grade	Thread	Depth (mMDRT)
Conductor	30/20	310/129	X52/X56	ST-2	122.0
Surface Casing	13.375	68	L80	BTC	849.1

IV. CEMENTING DATA

String Cemented	Cement Type	Dry Cmt Vol (sx)	Cement Additives	Mix Water (bbls)	Slurry Vol (bbls)	Slurry Density (ppg)	Cement to/from (mMDRT)	Csg Test Pressure (psi)
30" Lead	Class G	1228	1% CaCl ₂	151	256	15.9	402 – 250.1	-
13.375" Lead	Class G	1335	14.6 gal/10 bbl Econolite	413	526	12.5		-
13.375" Tail	AB Class G	726	14.6 gal/10bbl Econolite 0.5 gal/10bbl NF-5	88	150	15.8	849.1-76.23	2230

ABANDONMENT PLUGS

	Cement Type	Dry Cmt Vol (sx)	Cement Additives	Mix Water	Slurry Vol (bbls)	Slurry Density (ppg)	Cement to/from (mMDRT)	Csg Test Pressure (psi)
Plug #1a	Class G	335	0.1 gpb SCR-100L, 2 gpb Halad 413 L and 0.025 gpb NF-5	fresh		15.8	1325 – 1460	
Plug #1b	Class G	335	0.1 gpb SCR-100L, 2 gpb Halad 413 L and 0.025 gpb NF-5	fresh		15.8	1190-1325	
Plug #1c	Class G	335	2 gpb Halad 413 L and 0.025 gpb NF-5	fresh		15.8	1055 – 1190	

IV. CEMENTING DATA (cont'd)

ABANDONMENT PLUGS (continued)

	Cement Type	Dry Cmt Vol (sx)	Cement Additives	Mix Water	Slurry Vol (bbls)	Slurry Density (ppg)	Cement to/from (mMDRT)	Csg Test Pressure (psi)
Plug #1d	Class G	335	2 gpb Halad 413 L and 0.025 gpb NF-5	fresh		15.8	920-1055	
Plug #1e	Class G	407	0.025 gpb NF-5	Seawater		15.9	768 – 920	
Plug 2	Class G	145	1% CaC12 and 0.025 GPB NF-5	seawater		15.9	105-160	1000

V. SAMPLES, SIDEWALL CORES

Cuttings Samples

<u>Interval (m)</u>	<u>Type</u>	<u>Sets</u>
863 - 890m	Washed and dried samples every 27m	4
890 - 920m	Washed and dried samples every 30m	4
920 - 1430m	Washed and dried samples every 5m	4
1430 - 1500m	Washed and dried samples every 10m	4
1500 - 1905m	Washed and dried samples every 5m	4

One set of lightly washed palynology was collected over 30m intervals over the gross interval 863 – 1905m.

Conventional Cores

No conventional cores were cut at Beardie -1.

V. SAMPLES, SIDEWALL CORES (cont'd)
--

Sidewall Cores

BEARDIE-1 MSCT			
Core Number	Depth (m MD RT)	Core Length (mm)	Lithology
1	1887.0	26	Claystone
2	1870.0	27	Claystone
3	1845.0	20	Claystone
4	1795.5	30	Coal
5	1793.0	27	Claystone
6	1730.0		Misfire
7	1717.0	33	Sandstone
8	1706.0	35	Coal
9	1696.0		Misfire
10	1689.0	30	Sandstone
11	1687.5	25	Siltstone
12	1684.0		Misfire
13	1660.0	25	Sandstone
14	1657.0	30	Claystone
15	1597.0		Misfire
16	1544.0	20	Claystone
17	1504.0	20	Siltstone
18	1491.0		Misfire
19	1489.0	25	Siltstone/Coal
20	1468.0	35	Siltstone
21	1424.0		Misfire
22	1422.0	33	Siltstone
23	1419.0	20	Sandstone
24	1416.0	35	Sandstone

V. SAMPLES, SIDEWALL CORES (cont'd)
--

BEARDIE-1 MSCT (cont'd)			
Core Number	Depth (m MD RT)	Core Length (mm)	Lithology
25	1414.5	35	Sandstone
26	1412.5	25	Sandstone
27	1411.0	30	Sandstone
28	1410.0	35	Siltstone/Claystone
29	1382.0	35	Siltstone/Claystone
30	1369.0	35	Sandstone
31	1366.5	40	Sandstone
32	1354.0	30	Siltstone
33	1347.0		Misfire
34	1320.5	20	Sandstone
35	1315.0	30	Coal/Claystone
36	1310.0		Misfire
37	1289.0	25	Sandstone
38	1288.0	20	Sandstone
39	1284.0		Misfire
40	1276.0	30	Sandstone
41	1273.0	20	Sandstone
42	1262.5		
43	1258.0	35	Sandstone
44	1252.0		Misfire
45	1250.5		Misfire
46	1244.0		Misfire
47	1226.0	25	Siltstone
48	1223.0		Misfire
49	1218.0	25	Sandstone

V. SAMPLES, SIDEWALL CORES (cont'd)
--

BEARDIE-1 MSCT			
Core Number	Depth (m MD RT)	Core Length (mm)	Lithology
50	1212.0	20	Sandstone
51	1207.0		Misfire
52	1204.0	33	Sandstone
53	1198.0	40	Sandstone
54	1194.0	40	Claystone
55	1186.0	28	Siltstone
56	1160.0	30	Claystone
57	1140.0	30	Calcisiltite
58	1091.0	23	Sandstone
59	1080.0	30	Sandstone
60	1070.0	25	Arg. Calcisiltite

CST CORES

See APPENDIX 3 for Sidewall Core Descriptions.

VI. WIRELINE LOGS AND SURVEYS

Survey /Log	Company	Top (m MDRT)	Bottom (mMDRT)
Suite 1 Run at 1909.5m			
MWD Survey	Anadrill	907.95m	1905m
Gyro Survey	Scientific Drilling	185m	845m
DUAL AXIS DENSITY- PEX-HALS-LEHQT	Schlumberger	850.5 GR to Sea Floor	1909.5
FMI-DSI-HNGS-GR- LEHQT	Schlumberger	850.5	1909.5
MDT-GR-LEHQT	Schlumberger	1081.0	1750.0
DUAL CSAT-VSP	Schlumberger	178.0	1900.0
CST-GR4	Schlumberger	1070.0	1887.0
DSI (in casing)	Schlumberger	76.2	849.1

VII. SUMMARY OF FORMATION TEST PROGRAMME

SUITE	TYPE OF LOG	FROM	TO	RPT. SECT. / SUMMARY.	Time Since Last Circ / BHT
1	MDT-GR-LEHQT	1750	1081	33 points, GR depth correlation after each ten points	30.25 hrs/85.5°C @ 1759m

VIII. TEMPERATURE RECORD

SUITE 1

LABEL	TYPE OF LOG	FROM	TO	RPT. SECT. / SUMMARY.	Time Since Last Circ / BHT
1	DUAL AXIS DENSITY-PEX-HALS- LEHQT	1909.5	850	1740m - 1580	10.25 hrs/80.55°C
2	FMI-DSI-HNGS-GR-LEHQT	1909.5	850	1740m - 1580	16.2 hrs/83.89°C
3	MDT-GR-LEHQT	1750	1081	33 points, GR depth correlation after each ten points	30.25 hrs/85.5°C @ 1759m
4	DUAL CSAT-VSP	1900	178		36.20 hrs/88.89°C
5	CST-GR4	1887	1070	GR Depth correlation 1875m - 1850m	-
6	DSI-GR	850	Sea Floor	GR Depth correlation 875m - 850m	-

ESSO AUSTRALIA LTD

LWD/MWD Run Summary

WELL LOCATION DATA

Well Name:	Beardie-1	Licence Number:	Vic / L2
Field:	Wildcat	Primary Objective:	Latrobe Sands
Well Type:	Exploration	Water Depth:	51.2 m
AMG co-ords:		RT Elevation:	25.0 m
Local co-ords:	147°48'24"E, 38°15'16"S	Total Depth MDRT	1580

GENERAL WELL DATA

Date In / Out:	30-Jul-02 / 01-Aug-02	Run #:	1
Service Company:	Anadrill	Hole Size (in):	12-1/4"
LWD Engineers	W.Bertheux, C.Borbas	Inclination:	0.65
Esso Geologist:	C. Menhennitt, B. Menzel	Av. Azimuth:	220

MUD DATA

Mud Type:	KCl/PHPA/Poly/Glycol	Chlorides (mg/l):	35,000
Mud Weight (ppg)	9.8	KCL (%wt):	8.00
Viscosity (s/qt):	48	O/W/S:	-
PV: (cp):	18	Rmf (ohmm):	0.063 @ 20 degC
YP: (lbs/100 sq ft)	26	Rmc (ohmm):	0.128 @ 20 degC
API Filtrate (ml/30min)	3.8	Rm (ohmm):	0.076 @ 21 degC

DRILLING DATA

Mtrs Drilled:	731	RPM:	150
Av. ROP: (m/hr):	40.0	Flow Rate (gpm):	900
Av. WOB (K lbs):	17.0	SPM:	75
Av. Torq (ft/lbs):	4.9	Pressure (psi):	3250

BIT DATA

Bit Make:	Reed-Hycalog	Drilled Interval:	From	To	Dist.
Bit Type:	PDC		849	1580	731
Num Jets:	5	Reamed Interval:	0	0	0
Size (32 nds):	14				

TIME DATA

Date pick up tools:	30-Jul-02	Drilling Time:	34.62	Hrs
Time pick up tools:	15:30	Pump Hours:	39.72	Hrs
Date laid down Tools:	01-Aug-02	RT Trans Hours:	34.62	Hrs
Time laid down tools:	21:00	LWD Ream Hours:	0	Hrs
Time below RT:	46.0 hrs	Down Time:	0	Hrs

TOOL DATA

Tool Name:	PowerPulse	ARC8				
Tool S / Number:	231	8031				
Tool OD (in.):	8 ¼	8.25				
Bit/Sec./Carrier:	6.4bps/16Hz	6.4bps/16Hz				
Distance to bit (m)	29	21.5				

RUN SUMMARY

Loss of realtime ARC communication at 820m due to severely high shocks when drilling shoetrack.

POOH at 1580m for bit change due to low ROP.

BHA DATA

Element	Size OD	Length (m)	Cum Len (m)
12¼" PDC Bit	12 ¼"	0.32	0.32
N.B Stabilizer	12 ¼"	1.47	1.79
8" Pony Collar	8"	3.25	5.04
12 ¼" Stabilizer	12 ¼"	2.34	7.38
8¼" Drill Collar	8 ¼"	9.4	16.78
12 ¼" Stabilizer	12 ¼"	2.35	19.13
ARC8	8 3/8 "	5.73	24.86
PowerPulse	8 ¼"	8.52	33.38
8¼" Drill Collar	8 ¼"	28.24	61.62
XO	8 ¼"	1.1	62.72
HWDP	6 9/16"	17.5	80.22
Jars	6 ¼"	9.81	90.03
HWDP	6 ¼"	274.91	364.94

ESSO AUSTRALIA LTD

LWD/MWD Run Summary

WELL LOCATION DATA

Well Name:	Beardie-1	Licence Number:	Vic / L2
Field:	Wildcat	Primary Objective:	Latrobe Sands
Well Type:	Exploration	Water Depth:	51.2m
AMG co-ords:		RT Elevation:	25.0 m
Local co-ords:	147°48'24"E, 38°15'16"S	Total Depth MDRT	1905 m

GENERAL WELL DATA

Date In / Out:	01-Aug-02 / 04-Aug-02	Run #:	2
Service Company:	Anadrill	Hole Size (in):	12-1/4"
LWD Engineers:	W.Bertheux, C.Borbas	Inclination:	0.9
Esso Geologist:	C. Menhennitt, B. Menzel	Av. Azimuth:	210

MUD DATA

Mud Type:	KCl/PHPA/Poly/Glycol	Chlorides (mg/l):	35,500
Mud Weight (ppg):	9.8	KCL (%wt):	8
Viscosity (s/qt):	60	O/W/S:	
PV: (cp):	20	Rmf (ohmm):	0.097 @ 21 degC
YP: (lbs/100 sq ft):	32	Rmc (ohmm):	0.250 @ 21 degC
API Filtrate (ml/30min):	3.6	Rm (ohmm):	0.125 @ 21 degC

DRILLING DATA

Mtrs Drilled:	325	RPM:	88.0
Av. ROP: (m/hr):	8.00	Flow Rate (gpm):	825
Av. WOB (K lbs):	28.0	SPM:	95
Av. Torq (ft/lbs):	3.60	Pressure (psi):	3000

BIT DATA

Bit Make:	Reed Hycalog	<table border="1"> <thead> <tr> <th>From</th> <th>To</th> <th>Dist.</th> </tr> </thead> <tbody> <tr> <td>1580</td> <td>1905</td> <td>325</td> </tr> <tr> <td>0</td> <td>0</td> <td>0</td> </tr> </tbody> </table>	From	To	Dist.	1580	1905	325	0	0	0
From	To		Dist.								
1580	1905		325								
0	0		0								
Bit Type:	Insert										
Num Jets:	3										
Size (32 nds):	18										

TIME DATA

Date pick up tools:	01-Aug-02	Drilling Time:	32.98	Hrs
Time pick up tools:	22:00	Pump Hours:	41.4	Hrs
Date laid down Tools:	04-Aug-02	RT Trans Hours:	32.98	Hrs
Time laid down tools:	12:30	LWD Ream Hours:	0	Hrs
Time below RT:	61 hrs	Down Time:	0	Hrs

TOOL DATA

Tool Name:	PowerPulse	CDR9				
Tool S / Number:	833	9556				
Tool OD (in.):	8 ¼	9 ¼				
Bit/Sec./Carrier:	6bps / 16 Hz	6bps / 16 Hz				
Distance to bit (m)	31.32	21.43				

RUN SUMMARY

ARC tool from Run 1 laid out and backup CDR tool picked up.

Loss of realtime CDR communication due to intermittent contact between MWD and LWD tools.

Run 2 ended at TD of 1905m.

BHA DATA

Element	Size OD	Length (m)	Cum Len (m)
12¼" PDC Bit	12 ¼"	0.34	0.34
N.B Stabilizer	12 ¼"	1.47	1.81
8" Pony Collar	8"	3.25	5.06
12 ¼" Stabilizer	12 ¼"	2.34	7.40
8¼" Drill Collar	8 ¼"	9.42	16.82
12 ¼" Stabilizer	12 ¼"	2.35	19.17
ARC8	8 3/8"	8.03	27.2
PowerPulse	8 ¼"	8.53	35.73
8¼" Drill Collar	8 ¼"	121.23	156.96
XO	8 ¼"	1.1	158.06
HWDP	6 9/16"	17.5	175.56
Jars	6 ¼"	9.81	185.37
HWDP	6 ¼"	274.91	460.28

Figures



A4 Reusable Dividers
5 Rainbow Tabs
Re-order Code 85600

2913713

Figure 1. BEARDIE-1 LOCATION MAP

GIPPSLAND 2001

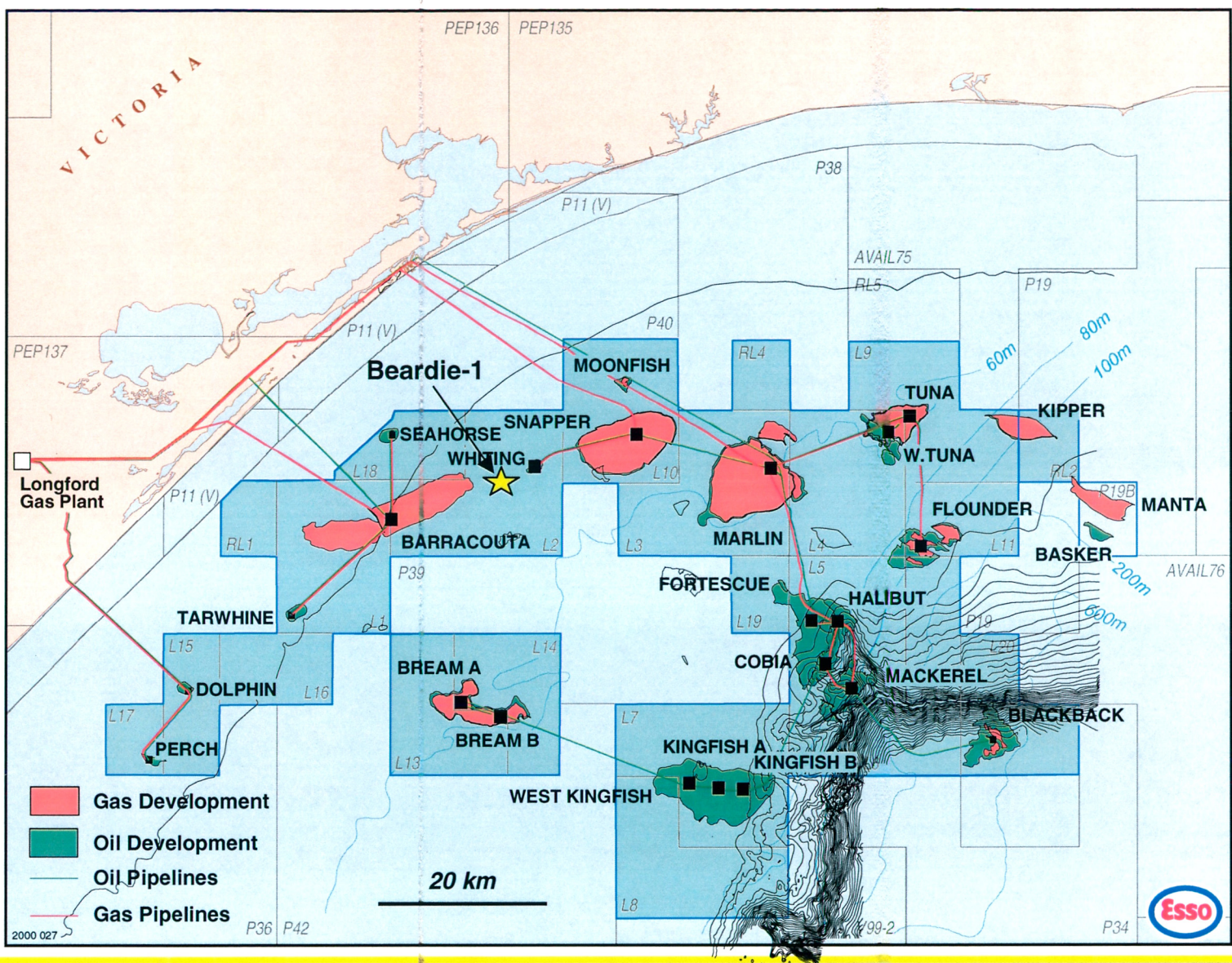

913713 021

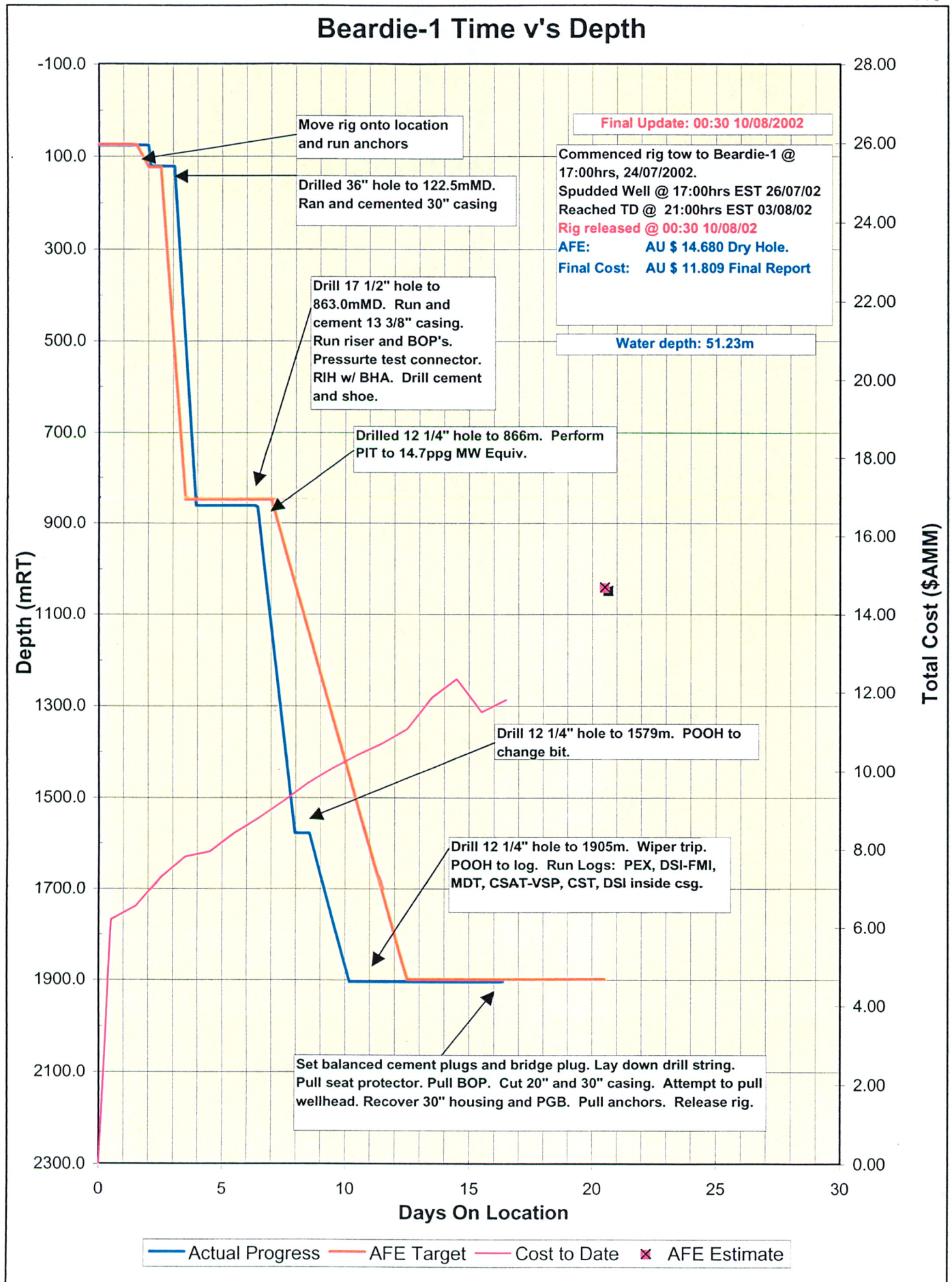

FIGURE 2

BEARDIE-1 WELLBORE SKETCH

PLANNED

ACTUAL (All depths LAT)

RT Elevation: 0m

Receive rig @ 1700 hours, 24 July 2002
Spud Beardie-1 @ 1700 hours, 26 July 2002

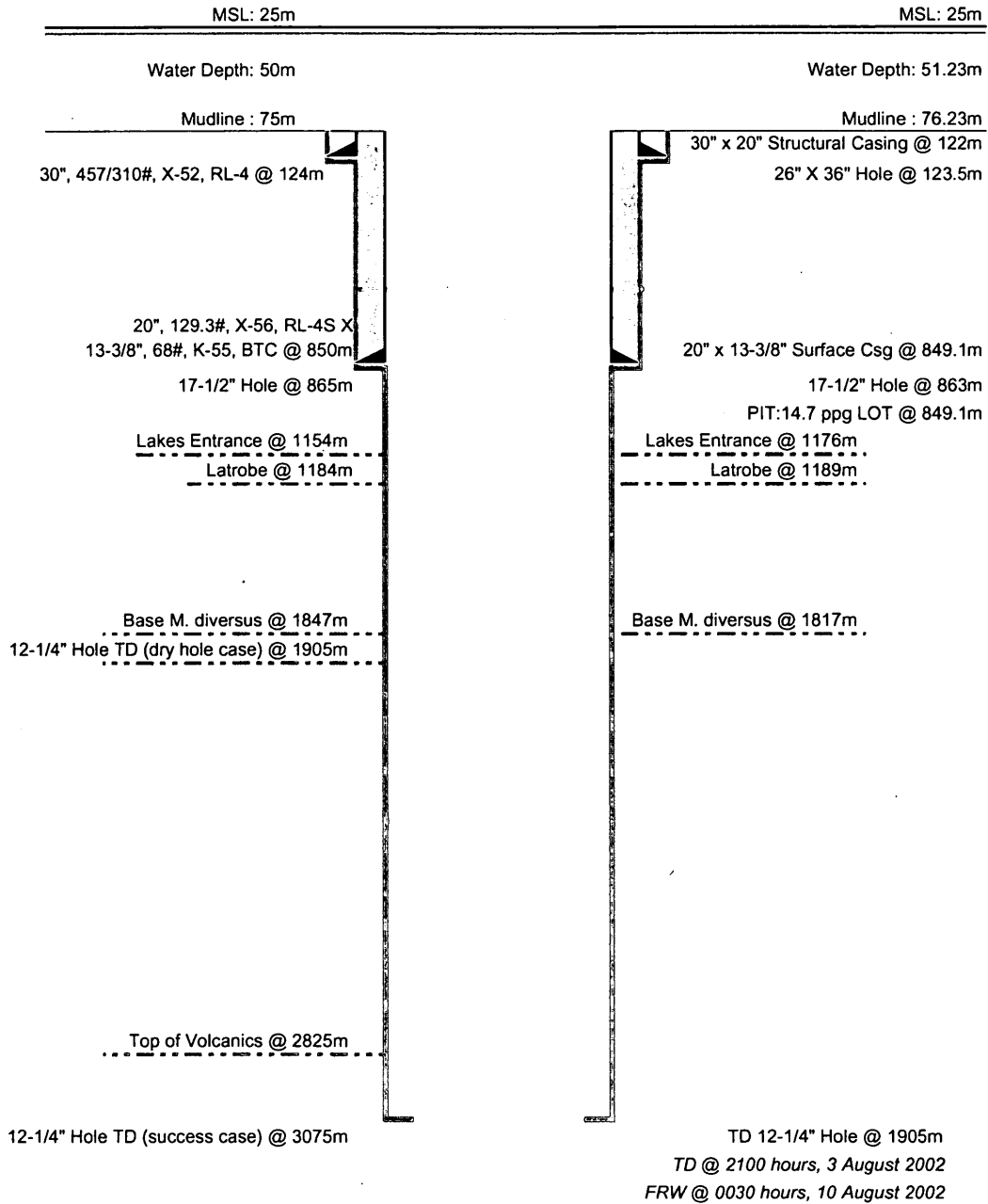

FIGURE 3

**WELLBORE SKETCH AFTER PLUGGING & ABANDONING
DIAMOND OFFSHORE OCEAN BOUNTY
BEARDIE-1**

**LOCATION: AGD 1966. Latitude 38° 15' 16.214" S. Longitude 147° 48' 24.643" E.
AMG Zone 55 Easting 570,594.15m, Northing 5,765,624.16m
Rig on Location 0800hr 25-Jul-2002. Rig released 0030 hours 10-Aug-2002**

ALL DEPTHS ARE LAT IN METERS FROM ROTARY TABLE (MD=TVD)

MSL @ 25m RT

WATER DEPTH = 51.23m

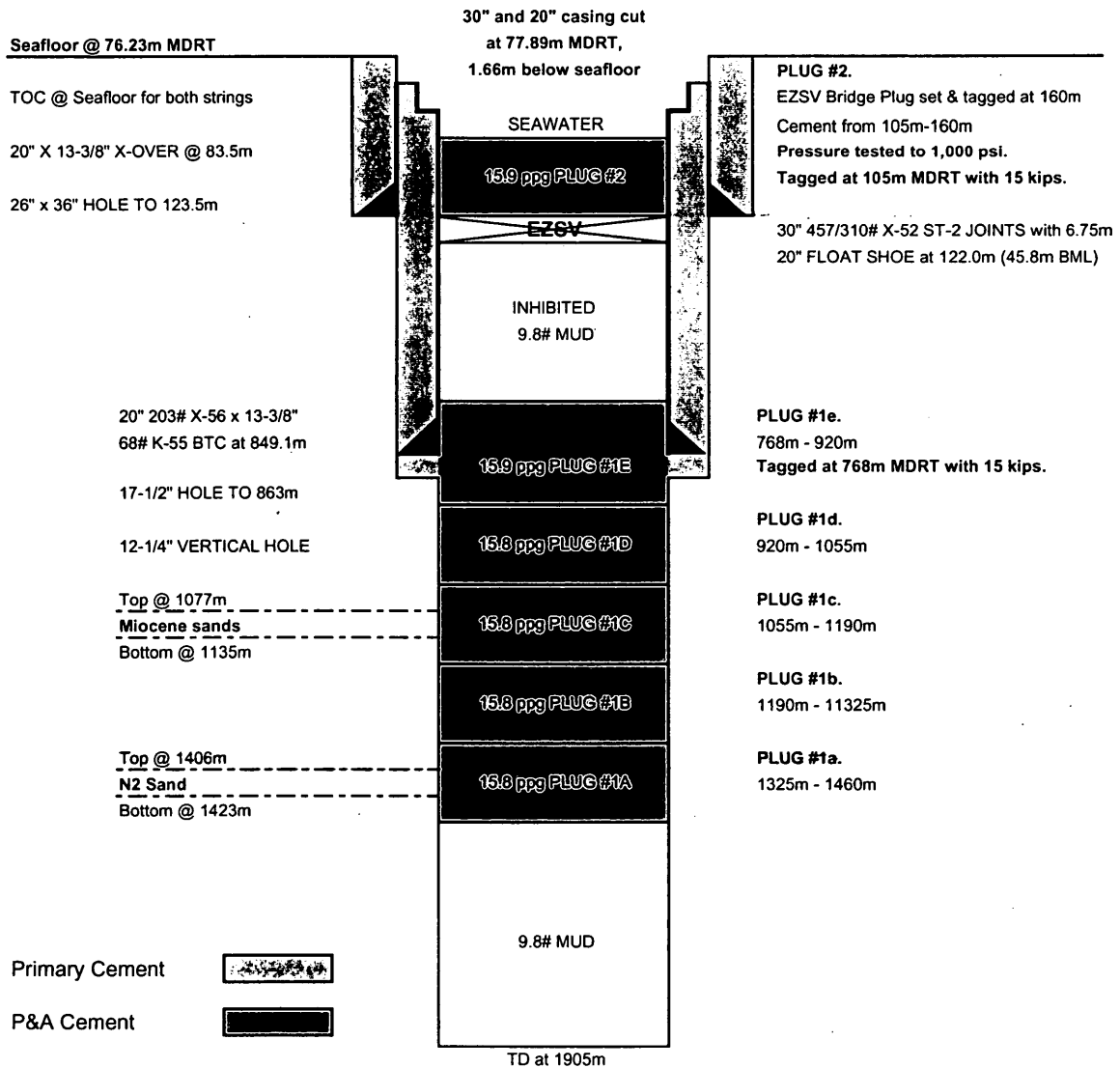

FIGURE 4

Beardie-1 Horner Plot

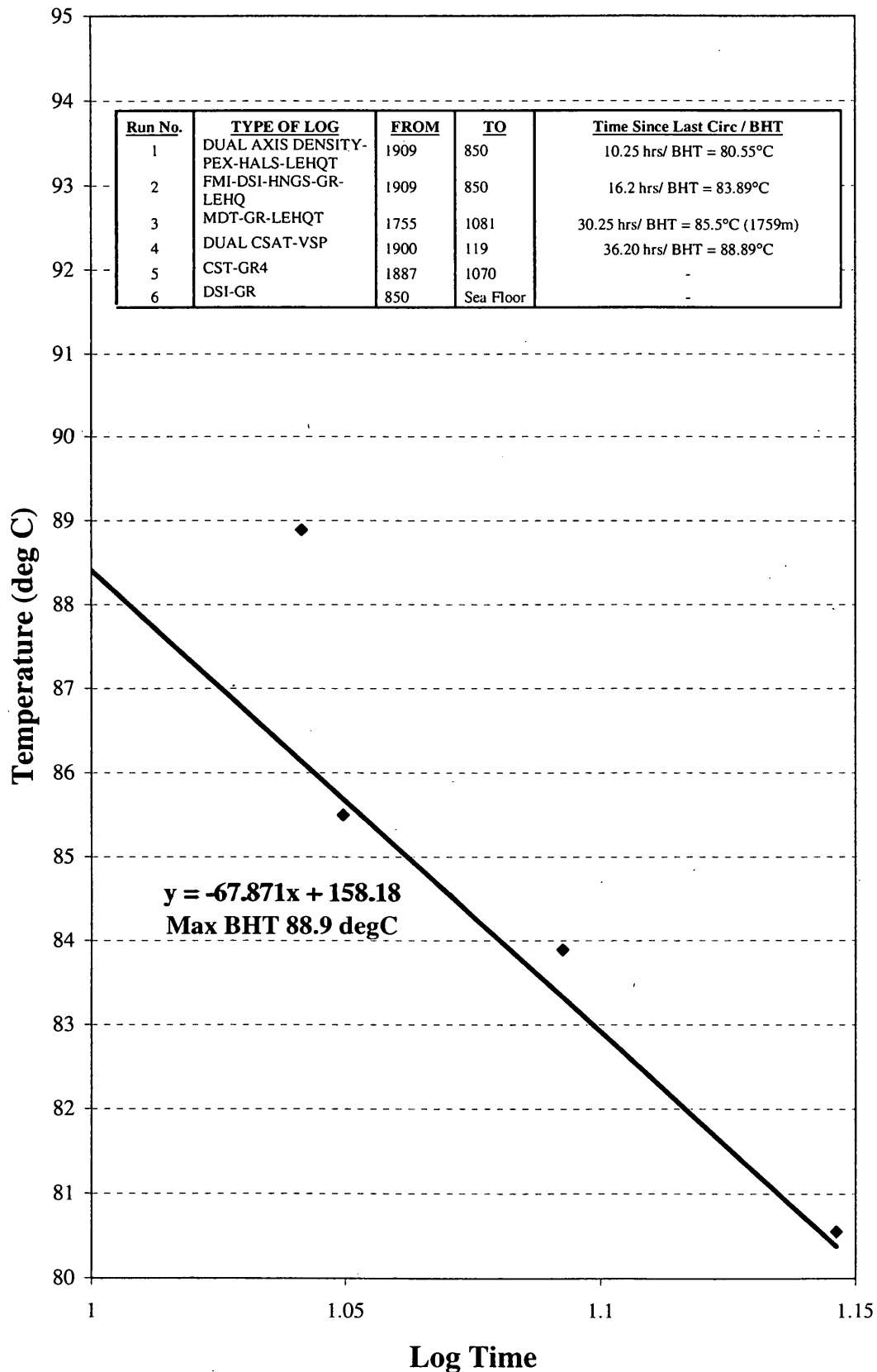

FIGURE 5

Appendicies

APPENDIX I

APPENDIX 1

LITHOLOGICAL DESCRIPTIONS

Beardie-1 Lithology / Show Descriptions

Interval (m)		%	Lithology / Show Description
From	To		
			Commenced drilling 12¼" section at 0340hrs on 31 st July, 2002. Returns from 863m. All depths are MDRT unless otherwise specified.
863	890	100	ARGILLACEOUS CALCILUTITE: very light grey to light grey, medium grey in part, abundant argillaceous matrix, trace carbonaceous specks, trace micro-fossils (forams), trace coarse quartz grains, trace nodular pyrite, trace crystalline calcite, nil to trace glauconite, generally soft, firm in part, amorphous to sub blocky. *Note: Cement contamination
890	920	100	ARGILLACEOUS CALCILUTITE: very light grey to light grey, medium grey in part, abundant argillaceous matrix, minor crystalline calcite, trace carbonaceous specks, trace micro-fossils (forams), trace medium to coarse quartz grains, trace nodular pyrite, nil to trace glauconite, generally soft, firm in part, amorphous to sub blocky.
920	925	100	ARGILLACEOUS CALCILUTITE: as above
925	930	100	ARGILLACEOUS CALCILUTITE: as above
930	935	100	ARGILLACEOUS CALCILUTITE: light grey to medium light grey, medium grey in part, abundant argillaceous matrix, minor to common crystalline calcite, trace carbonaceous specks, trace micro-fossils (forams), trace medium to coarse quartz grains, trace nodular and disseminated pyrite, trace glauconite, soft to firm, amorphous to sub blocky.
935	940	100	ARGILLACEOUS CALCILUTITE: as above
940	945	100	ARGILLACEOUS CALCILUTITE: as above
945	950	100	ARGILLACEOUS CALCILUTITE: as above
955	960	100	ARGILLACEOUS CALCILUTITE: light grey to medium light grey, medium grey to light brownish grey in part, abundant argillaceous matrix, minor to common crystalline calcite, trace carbonaceous specks, trace micro-fossils (forams), trace medium to coarse quartz grains, nil to trace disseminated pyrite, trace glauconite, soft to firm, amorphous to sub blocky.
960	965	100	ARGILLACEOUS CALCILUTITE: as above
965	970	100	ARGILLACEOUS CALCILUTITE: as above
970	975	100	ARGILLACEOUS CALCILUTITE: light grey to medium light grey, medium grey in part, abundant argillaceous matrix, minor to common crystalline calcite, trace carbonaceous specks, trace micro-fossils (forams), trace medium to coarse quartz grains, trace nodular and disseminated pyrite, trace glauconite, soft to firm, amorphous to sub blocky.
975	980	100	ARGILLACEOUS CALCILUTITE: as above
980	985	100	ARGILLACEOUS CALCILUTITE: as above
985	990	100	ARGILLACEOUS CALCILUTITE: light grey to medium light grey, medium grey in part, abundant argillaceous matrix, minor to common crystalline calcite, trace carbonaceous specks, trace micro-fossils (forams), trace medium to coarse quartz grains, trace nodular and disseminated pyrite, trace glauconite, soft to firm, amorphous to sub blocky. Grades to very calcareous Claystone in part.
990	995	100	ARGILLACEOUS CALCILUTITE: white, light grey to medium light grey, medium grey in part, abundant argillaceous matrix, minor to common crystalline calcite, trace carbonaceous specks, trace micro-fossils (forams), trace fine to coarse quartz grains, trace disseminated pyrite, trace glauconite, soft to firm, amorphous to sub blocky. Grades to very calcareous Claystone in part.
995	1000	100	ARGILLACEOUS CALCILUTITE: white, light brownish grey to medium light grey, soft to firm, amorphous to blocky, abundant argillaceous matrix, trace crystalline calcite, trace carbonaceous specks, trace micro-fossils (forams), trace fine to coarse quartz grains, trace disseminated pyrite, rare glauconite.

Beardie-1 Lithology / Show Descriptions

Interval (m)		%	Lithology / Show Description
From	To		
1000	1005	90	ARGILLACEOUS CALCILUTITE: white, light brownish grey, soft to firm, amorphous to blocky, abundant argillaceous matrix, trace crystalline calcite, trace carbonaceous specks, trace disseminated pyrite, minor glauconite.
		10	SAND: quartzose, soft, disaggregated, medium to coarse grained, rarely very coarse, subangular to rounded, poor sphericity, no visible cement. Good inferred porosity. No show.
1005	1010	95	ARGILLACEOUS CALCILUTITE: as above
		5	SAND: as above
1010	1015	100	ARGILLACEOUS CALCILUTITE: very light grey, light brownish grey, mottled, soft to firm, amorphous to blocky, abundant argillaceous matrix, trace crystalline calcite, trace carbonaceous specks, trace forams, minor glauconite. Trace sand grains as above. Grades to Calcisiltite in small part.
1015	1020	100	ARGILLACEOUS CALCILUTITE: as above
1020	1025	100	ARGILLACEOUS CALCILUTITE: as above
1025	1030	100	ARGILLACEOUS CALCILUTITE: as above
1030	1035	100	ARGILLACEOUS CALCILUTITE: very light grey, light brownish grey, mottled, soft to firm, amorphous to blocky, abundant argillaceous matrix, trace crystalline calcite, trace carbonaceous specks, trace forams, trace glauconite. Grades to argillaceous Calcisiltite and calcareous Claystone in part.
1035	1040	100	ARGILLACEOUS CALCILUTITE: very light grey, light brownish grey, mottled, soft to firm, amorphous to blocky, abundant argillaceous matrix, trace crystalline calcite, trace carbonaceous specks, trace forams, trace glauconite. Grades to argillaceous Calcisiltite in part. Trace sand grains.
1040	1045	100	ARGILLACEOUS CALCILUTITE: light olive grey, light brownish grey, white, mottled, soft to firm, amorphous to blocky, abundant argillaceous matrix, trace crystalline calcite, trace carbonaceous specks, trace forams, trace glauconite. Grades to argillaceous Calcisiltite in part. Grades to very calcareous Siltstone and Claystone in part. Trace sand grains.
1045	1050	100	ARGILLACEOUS CALCILUTITE: as above. Trace quartz sand as above.
1050	1055	95	ARGILLACEOUS CALCILUTITE: as above
		5	SAND: as above
1055	1060	100	ARGILLACEOUS CALCILUTITE: as above
1060	1065	95	ARGILLACEOUS CALCISILTITE: light olive grey, light brownish grey, white, mottled, soft to firm, amorphous to blocky, common argillaceous matrix, trace crystalline calcite, trace carbonaceous specks, trace forams, trace glauconite. Grades to argillaceous Calcilutite in part. Grades to very calcareous Siltstone and Claystone in part.
		5	SAND: as above.
1065	1070	100	ARGILLACEOUS CALCISILTITE: light olive grey, light brownish grey, white, mottled, soft to firm, amorphous to blocky, common argillaceous matrix, trace crystalline calcite, trace carbonaceous specks, trace forams, trace glauconite. Grades to argillaceous Calcilutite in part. Grades to very calcareous Siltstone and Claystone in part.
		Tr	SAND: as above.
1070	1075	90	ARGILLACEOUS CALCISILTITE: light olive grey, light brownish grey, white, mottled, soft to firm, amorphous to blocky, common argillaceous matrix, trace crystalline calcite, trace carbonaceous specks, trace forams, trace glauconite. Grades to argillaceous Calcilutite in part. Grades to very calcareous Siltstone and rare calcareous Claystone in part.
		10	SAND: quartzose, soft, disaggregated, fine to coarse grained, rarely very coarse, subangular to rounded, poor sphericity, no visible cement. Good inferred porosity. No show.

Beardie-1 Lithology / Show Descriptions

Interval (m)		%	Lithology / Show Description
From	To		
1075	1080	80	SAND: quartzose, soft, disaggregated, fine to very coarse grained, clear to dominantly frosted, subangular to rounded, poor to occasionally good sphericity, no visible cement. Very good inferred porosity. No show.
		20	ARGILLACEOUS CALCISILTITE: light olive grey, light brownish grey, white, mottled, soft to firm, amorphous to blocky, common argillaceous matrix, trace crystalline calcite, trace carbonaceous specks, trace forams, trace glauconite. Grades to argillaceous Calcilutite in part. Grades to very calcareous Siltstone and rare calcareous Claystone in part.
1080	1085	60	SAND: quartzose, soft, disaggregated, fine to very coarse grained, clear to dominantly frosted, subangular to rounded, poor to occasionally good sphericity, no visible cement. Very good inferred porosity. No show.
		40	ARGILLACEOUS CALCISILTITE: light olive grey, light brownish grey, white, mottled, soft to firm, amorphous to blocky, common argillaceous matrix, trace crystalline calcite, trace carbonaceous specks, trace forams, trace glauconite. Grades to argillaceous Calcilutite in part and very calcareous Siltstone and rare calcareous Claystone in part.
1085	1090	70	ARGILLACEOUS CALCILUTITE: white to light greyish brown, mottled, soft to firm, amorphous to blocky, common argillaceous matrix, very arenaceous, trace carbonaceous specks, trace forams, trace glauconite. Grades to very arenaceous Sandstone in part.
		30	SANDSTONE: quartzose, soft to firm, disaggregated to aggregated, fine to very coarse grained, clear to dominantly frosted, subangular to rounded, poor to occasionally good sphericity, common argillaceous and calcitic matrix. Poor visible porosity. No show.
1090	1095	80	SANDSTONE: quartzose, soft to firm, disaggregated to aggregated, fine to very coarse grained, clear to dominantly frosted, subangular to rounded, poor to occasionally good sphericity, common argillaceous and calcitic matrix. Poor visible porosity. No show.
		20	ARGILLACEOUS CALCILUTITE:
1095	1100	70	SANDSTONE: as above.
		30	ARGILLACEOUS CALCILUTITE: as above.
1100	1105	60	ARENACEOUS CALCILUTITE: as above.
		40	SANDSTONE: as above.
1105	1110	100	ARENACEOUS CALCILUTITE: white, mottled, soft to firm, amorphous to blocky, common argillaceous matrix, commonly arenaceous, trace carbonaceous specks, trace glauconite. Grades to very calcareous Sandstone in part.
1110	1115	100	ARENACEOUS CALCILUTITE: white, mottled, light olive grey, soft to firm, amorphous to blocky, common argillaceous matrix, commonly arenaceous, trace carbonaceous specks, trace glauconite. Grades to very calcareous Sandstone in part.
1115	1120	100	ARENACEOUS CALCILUTITE: as above.
1120	1125	50	ARENACEOUS CALCILUTITE: as above.
		50	ARGILLACEOUS CALCISILTITE: light olive grey, light brownish grey, white, mottled, soft to firm, amorphous to blocky, minor argillaceous matrix, trace crystalline calcite, trace carbonaceous specks, trace forams, trace glauconite.
1125	1130	60	ARGILLACEOUS CALCISILTITE: light olive grey, light grey, white, mottled, soft to firm, amorphous to blocky, minor argillaceous matrix, trace carbonaceous specks, trace forams, trace glauconite.
		40	CALCILUTITE: as above. Grades to very calcareous, slightly arenaceous Claystone in part.
1130	1135	50	ARGILLACEOUS CALCISILTITE: as above.
		50	CALCILUTITE: as above.
1135	1140	100	ARGILLACEOUS CALCISILTITE: light olive grey, light grey, white, mottled, soft to firm, amorphous to blocky, minor argillaceous matrix, arenaceous, trace carbonaceous specks, trace forams, rare glauconite. Grades to Argillaceous Calcilutite in part.

Beardie-1 Lithology / Show Descriptions

Interval (m)		%	Lithology / Show Description
From	To		
1140	1145	100	ARGILLACEOUS CALCISILTITE: light olive grey, light grey, white, mottled, soft to firm, amorphous to blocky, minor argillaceous matrix, arenaceous, trace carbonaceous specks, trace forams, rare glauconite. Grades to Argillaceous Calcilutite in part.
1145	1150	100	ARGILLACEOUS CALCILUTITE: light olive grey, olive grey, soft, amorphous to sub blocky, common argillaceous matrix, trace carbonaceous specks, trace glauconite. Grades to very calcareous Claystone and argillaceous Calcisiltite in part.
1150	1155	100	ARGILLACEOUS CALCILUTITE grading to calcareous Claystone in part.
1155	1160	60	ARGILLACEOUS CALCILUTITE: as above.
		40	ARGILLACEOUS CALCISILTITE: light olive grey, light grey, white, mottled, soft to firm, amorphous to blocky, minor argillaceous matrix, arenaceous, trace carbonaceous specks, trace forams, rare glauconite. Grades to Argillaceous Calcilutite in part.
1160	1165	60	ARGILLACEOUS CALCILUTITE: as above.
		40	ARGILLACEOUS CALCISILTITE: as above
1165	1170	70	ARGILLACEOUS CALCILUTITE: as above.
		30	ARGILLACEOUS CALCISILTITE: as above
1170	1175	80	ARGILLACEOUS CALCILUTITE: as above.
		20	ARGILLACEOUS CALCISILTITE: as above
1175	1180	90	ARGILLACEOUS CALCILUTITE: very light grey to light olive grey, soft to firm, amorphous to sub blocky, argillaceous, rare nodular and disseminated pyrite, abundant forams – spherical and “Globigerina”, minor granular green and dark green medium to coarse grains of glauconite. Grades to calcareous Claystone.
		10	SAND: quartzose, soft, disaggregated, fine to very coarse grained, clear to dominantly frosted, subangular to rounded, poor sorting, poor to occasionally good sphericity, no visible cement. Interlaminated with Calcilutite. No show.
1180	1185	100	ARGILLACEOUS CALCILUTITE: very light grey to light olive grey, soft to firm, amorphous to sub blocky, argillaceous, rare nodular and disseminated pyrite, common forams – spherical and “Globigerina”, minor granular green and dark green medium to coarse grains of glauconite and glauconitic clay, rare quartz grains. Grades to calcareous Claystone.
1185	1190	100	CLAYSTONE: very light grey to light olive grey, mottled pale yellowish brown, white, soft, amorphous to sub blocky, argillaceous, trace disseminated pyrite, common sideritic staining, minor granular green and dark green medium to coarse grains of glauconite and glauconitic clay, rare quartz grains.
1190	1195	80	SANDSTONE: quartzose, soft to firm, disaggregated, medium to very coarse grained, occasionally granular, clear to dominantly frosted, subangular to rounded, poor to occasionally good sphericity. Common microcrystalline pyrite nodules and cement and glauconite as grains and cement. Good visible porosity. No show.
		20	CLAYSTONE: as above.
1195	1200	100	SANDSTONE: quartzose, very light grey, soft to firm, disaggregated, medium to granular, clear to dominantly opaque, subangular to rounded, moderate sorting, poor to occasionally good sphericity. Common microcrystalline pyrite nodules and cement and glauconite as grains and cement. Good visible porosity. No show.
1200	1205	100	SANDSTONE: as above
1205	1210	70	SANDSTONE: quartzose, very light grey, soft to firm, disaggregated, medium to granular, clear to dominantly opaque, subangular to rounded, moderate sorting, poor to occasionally good sphericity. Common microcrystalline pyrite nodules and cement and glauconite as grains and cement. Good visible porosity. No show.
		30	SILTSTONE: light grey and yellowish brown, soft, slightly argillaceous, sideritic, pyritic, trace glauconite.

Beardie-1 Lithology / Show Descriptions

Interval (m)		%	Lithology / Show Description
From	To		
1210	1215	80	SANDSTONE: as above – becoming medium to very coarse grained.
		20	SILTSTONE: as above.
1215	1220	80	SANDSTONE: quartzose, very light grey, disaggregated, medium to granular, trace fine, clear to dominantly opaque, subangular to rounded, moderate sorting, poor to occasionally good sphericity, minor to common microcrystalline pyrite nodules and cement, minor glauconite as grains and cement. Good visible porosity. No show.
		20	SILTSTONE: light grey and yellowish brown, soft, common argillaceous matrix, sideritic, pyritic, trace glauconite.
1220	1225	90	SANDSTONE: quartzose, very light grey, disaggregated, fine to medium, trace coarse, clear to dominantly opaque, subangular to rounded, occasionally angular, moderately well sorted, moderate to occasionally good sphericity, minor microcrystalline pyrite nodules and cement, rare to minor glauconite as grains and cement. Good visible porosity. No show.
		10	SILTSTONE: as above.
1225	1230	70	SANDSTONE: as above, trace very coarse grains.
		30	SILTSTONE: as above. *Note: weak yellow fluorescence from Glycol in siltstone.
1230	1235	30	SANDSTONE: as above, trace very coarse grains.
		70	SILTSTONE: as above, becoming increasingly argillaceous. *Note: weak yellow fluorescence from Glycol in siltstone.
1235	1240	80	SANDSTONE: as above, trace very coarse grains.
		20	SILTSTONE: as above, becoming increasingly argillaceous. *Note: weak yellow fluorescence from Glycol in siltstone.
1240	1245	30	SANDSTONE: as above, trace very coarse grains.
		70	SILTSTONE: as above, occasionally firm, becoming increasingly argillaceous. *Note: weak yellow fluorescence from Glycol in siltstone.
1245	1250	40	SANDSTONE: quartzose, very light grey, disaggregated, predominantly fine to medium, trace coarse, trace very fine grained cemented aggregates, clear to dominantly opaque, subangular to rounded, occasionally angular, moderately well sorted, moderate to occasionally good sphericity, minor microcrystalline pyrite nodules and cement, rare to minor glauconite as grains and cement. Good visible porosity. No show.
		60	SILTSTONE: light grey and yellowish brown, soft, common argillaceous matrix, minor very fine quartz, sideritic, pyritic, trace glauconite.
1250	1255	90	SANDSTONE: quartzose, very light grey, disaggregated, medium to very coarse, trace fine, clear to dominantly opaque, subangular to rounded, trace angular, moderately sorted, poor to occasionally good sphericity, minor microcrystalline pyrite nodules and cement, minor glauconite as grains and cement. Good visible porosity. No show.
		10	SILTSTONE: light grey and yellowish brown, soft, common argillaceous matrix, trace very fine quartz, sideritic, pyritic, trace glauconite.
1255	1260	80	SANDSTONE: as above.
		20	SILTSTONE: as above.
1260	1265	90	SANDSTONE: quartzose, very light grey, disaggregated, coarse to granule, trace fine to medium, clear to dominantly opaque, subangular to rounded, trace angular, poorly to moderately sorted, poor to occasionally good sphericity, rare to minor microcrystalline pyrite nodules and cement, trace light grey argillaceous matrix, trace glauconite. Good visible porosity. No show.
		10	SILTSTONE: as above.
		Tr	COAL: moderate brown to predominantly brownish black, moderately firm to firm, brittle, blocky to sub conchoidal fracture, earthy to sub vitreous lustre.

Beardie-1 Lithology / Show Descriptions

Interval (m)		%	Lithology / Show Description
From	To		
1265	1270	80	SANDSTONE: as above.
		20	SILTSTONE: as above.
		Tr	COAL: as above.
1270	1275	80	COAL: as above.
		20	SANDSTONE: as above.
1275	1280	80	SANDSTONE: quartzose, very light grey, disaggregated, coarse to granule, trace fine to medium, clear to dominantly opaque, subangular to rounded, trace angular, poorly to moderately sorted, poor to occasionally good sphericity, rare to minor microcrystalline pyrite nodules and cement, trace light grey argillaceous matrix, trace glauconite. Good visible porosity. No show.
		20	SILTSTONE: light grey and yellowish brown, soft, common argillaceous matrix, trace very fine quartz, sideritic, trace pyrite, trace glauconite.
		Tr	COAL: as above.
1280	1285	100	SANDSTONE: as above.
		Tr	SILTSTONE: as above.
		Tr	COAL: as above.
1285	1290	100	SANDSTONE: as above.
		Tr	SILTSTONE: as above.
		Tr	COAL: as above.
1290	1295	100	SANDSTONE: as above, rare to minor fine to medium.
		Tr	COAL: as above.
1295	1300	100	SANDSTONE: as above.
		Tr	COAL: as above.
1300	1305	100	SANDSTONE: as above, rare to minor fine to medium.
		Tr	COAL: as above.
1305	1310	90	SANDSTONE: as above, rare to minor fine to medium.
		10	COAL: generally as above, becoming silty in part.
1310	1315	90	SANDSTONE: generally as above, predominantly medium to very coarse, minor silty matrix.
		10	COAL: generally as above, becoming silty in part.
1315	1320	100	SANDSTONE: quartzose, very light grey, disaggregated, medium to coarse, trace fine and very coarse, clear to dominantly opaque, subangular to rounded, trace angular, poorly to moderately sorted, poor to occasionally good sphericity, rare to trace microcrystalline pyrite nodules and cement, trace light grey argillaceous matrix, trace glauconite. Good visible porosity. No show.
1320	1325	100	SANDSTONE: as above.
1325	1330	100	SANDSTONE: as above.
		Tr	COAL: moderate brown to predominantly brownish black, moderately firm to firm, brittle, blocky to sub conchoidal fracture, earthy to sub vitreous lustre, silty in part.
1330	1335	100	SANDSTONE: as above.
		Tr	COAL: as above.
1335	1340	100	SANDSTONE: quartzose, very light grey, predominantly disaggregated with common hard calcite cemented fine aggregates, fine to medium, trace coarse, clear to dominantly opaque, subangular to rounded, trace angular, moderately to well sorted, poor to good sphericity, localised strong calcite cement, rare to trace microcrystalline pyrite nodules and cement, trace light grey argillaceous matrix, trace glauconite. Poor to Good visible porosity. 30% dull yellow direct fluorescence in sample interpreted as Glycol fluorescence in cemented aggregates.
		Tr	COAL: as above.

Beardie-1 Lithology / Show Descriptions

Interval (m)		%	Lithology / Show Description
From	To		
1340	1345	90	SANDSTONE: quartzose, very light grey, disaggregated, fine to medium, trace coarse, clear to dominantly opaque, subangular to rounded, trace angular, moderately to well sorted, poor to good sphericity, trace calcite cement, rare to trace microcrystalline pyrite cement, trace light brownish grey argillaceous matrix, trace glauconite. Good visible porosity. No shows.
		10	COAL: as above.
1345	1350	20	SANDSTONE: as above.
		80	COAL: as above.
1350	1355	20	SANDSTONE: as above.
		60	COAL: as above.
		20	SILTSTONE: light brownish grey to moderate brown, soft, common argillaceous matrix, trace very fine quartz, minor carbonaceous material.
1355	1360	70	SANDSTONE: quartzose, very light grey, disaggregated, medium to coarse, trace fine and very coarse, clear to dominantly opaque, subangular to rounded, trace angular, moderately to poorly sorted, poor to good sphericity, trace calcite cement, trace microcrystalline pyrite cement, trace light brownish grey argillaceous matrix, trace glauconite. No shows.
		20	COAL: as above.
		10	SILTSTONE: as above.
1360	1365	80	SANDSTONE: as above.
		Tr	COAL: as above.
		20	SILTSTONE: as above.
1365	1370	95	SANDSTONE: as above.
		5	COAL: as above.
1370	1375	95	SANDSTONE: generally as above, becoming coarse to very coarse.
		5	COAL: as above.
1375	1380	95	SANDSTONE: as above.
		5	COAL: as above.
1380	1385	60	SANDSTONE: quartzose, very light grey, disaggregated, medium to coarse, trace fine and very coarse, clear to dominantly opaque, subangular to rounded, trace angular, trace quartz overgrowths, moderately to poorly sorted, poor to good sphericity, trace calcite cement, trace microcrystalline pyrite cement, trace light brownish grey argillaceous matrix, trace glauconite. No shows.
		30	COAL: moderate brown to brownish black, moderately firm to firm, brittle, blocky to sub conchoidal fracture, earthy to sub vitreous lustre, silty in part.
		10	SILTSTONE: light brownish grey to moderate brown, soft, common argillaceous matrix, trace very fine quartz, common carbonaceous material
1385	1390	40	SANDSTONE: as above
		30	COAL: as above
		20	SILTSTONE: as above
1390	1395	90	SANDSTONE: generally as above, trace hard aggregates, abundant rock flour in sample.
		10	COAL: as above
		Tr	SILTSTONE: as above
1395	1400	80	SANDSTONE: as above
		10	COAL: as above
		10	SILTSTONE: as above
1400	1405	30	SANDSTONE: as above
		40	COAL: generally as above, interbedded with siltstone.
		30	SILTSTONE: as above

Beardie-1 Lithology / Show Descriptions

Interval (m)		%	Lithology / Show Description
From	To		
1405	1410	30	SANDSTONE: as above
		70	COAL: as above
		Tr	SILTSTONE: as above
1410	1415	40	SANDSTONE: quartzose, very light grey, disaggregated, fine to medium, trace coarse, trace very fine, clear to dominantly opaque, subangular to rounded, trace angular, moderately to well sorted, poor to good sphericity, trace calcite cement, trace microcrystalline pyrite cement, trace light brownish grey argillaceous matrix, trace glauconite. No shows.
		60	SILTSTONE: light brownish grey to moderate brown, soft, common argillaceous matrix, trace very fine quartz, trace disseminated pyrite, common carbonaceous material.
		Tr	COAL: moderate brown to brownish black, moderately firm to firm, brittle, blocky to sub conchoidal fracture, earthy to sub vitreous lustre, silty in part.
1415	1420	50	SANDSTONE: as above
		50	SILTSTONE: as above
		Tr	COAL: as above
1420	1425	100	SANDSTONE: quartzose, very light grey, disaggregated, medium to coarse, trace fine and very coarse, clear to dominantly opaque, subangular to rounded, trace angular, trace quartz overgrowths, moderately to poorly sorted, poor to good sphericity, trace calcite cement, trace microcrystalline pyrite cement, trace light brownish grey argillaceous matrix, trace glauconite. No shows.
		Tr	SILTSTONE: as above
		Tr	COAL: as above
1425	1430	100	SANDSTONE: as above
		Tr	COAL: as above
1430	1435	-	Sample missed due to high ROP
1435	1440	100	SANDSTONE: as above
		Tr	COAL: as above
1440	1445	-	Sample missed due to high ROP
1445	1450	100	SANDSTONE: quartzose, very light grey, disaggregated, medium to coarse, trace fine and very coarse to granule, clear to dominantly opaque, subangular to rounded, trace angular, trace quartz overgrowths, moderately to poorly sorted, poor to good sphericity, trace calcite cement, trace microcrystalline pyrite cement, trace glauconite. No shows.
		-	Sample missed due to high ROP
		-	Sample missed due to high ROP
1450	1455	-	Sample missed due to high ROP
1455	1460	100	SANDSTONE: as above
1460	1465	-	Sample missed due to high ROP
1465	1470	100	SANDSTONE: as above
1470	1475	-	Sample missed due to high ROP
1475	1480	100	SANDSTONE: as above
1480	1485	-	Sample missed due to high ROP
1485	1490	90	SANDSTONE: as above
		10	SILTSTONE: light brownish grey to moderate brown, soft, common argillaceous matrix, trace very fine quartz, trace disseminated pyrite, common carbonaceous material and coaly laminae.
1490	1495	-	Sample missed due to high ROP
1495	1500	90	SANDSTONE: as above.
		10	SILTSTONE: as above.
1500	1505	100	SANDSTONE: as above.
1505	1510	80	SANDSTONE: as above.
		20	COAL: as above
		Tr	SILTSTONE: as above.

Beardie-1 Lithology / Show Descriptions

Interval (m)		%	Lithology / Show Description
From	To		
1510	1515	70	SANDSTONE: quartzose, very light grey, disaggregated, medium to coarse, trace fine and very coarse to granule, clear to dominantly opaque, subangular to rounded, trace angular, trace quartz overgrowths, moderately to poorly sorted, poor to good sphericity, trace calcite cement. No shows.
		5	COAL: moderate brown to brownish black, moderately firm to firm, brittle, blocky to sub conchoidal fracture, earthy to sub vitreous lustre, very silty in part.
		25	SILTY CLAYSTONE: white to very light grey, soft, dispersive, finely interlaminated with silty coal in part, grading to argillaceous siltstone.
1515	1520	80	SANDSTONE: as above
		10	COAL: as above.
		10	SILTY CLAYSTONE: as above
1520	1525	80	SANDSTONE: as above
		10	COAL: as above.
		10	SILTY CLAYSTONE: as above
1525	1530	100	SANDSTONE: quartzose, very light grey, disaggregated, predominantly medium to coarse, trace fine and very coarse, clear to dominantly opaque, subangular to rounded, trace angular in coarser grains, trace quartz overgrowths, moderately to poorly sorted, poor to good sphericity, trace calcite cement. No shows.
		Tr	COAL: as above.
		Tr	SILTY CLAYSTONE: as above
		100	SANDSTONE: as above, trace pyrite cement.
1530	1535	Tr	COAL: as above.
		100	SANDSTONE: quartzose, very light grey, disaggregated, predominantly medium to coarse, trace fine, clear to dominantly opaque, subangular to rounded, trace angular in coarser grains, trace quartz overgrowths, moderately to poorly sorted, poor to good sphericity, trace calcite cement. No shows.
1535	1540	Tr	COAL: as above.
		100	SANDSTONE: quartzose, very light grey, disaggregated, medium to predominantly coarse, trace fine and very coarse, clear to dominantly opaque, subangular to rounded, trace angular in coarser grains, trace quartz overgrowths, trace pyrite cement, moderately to poorly sorted, poor to good sphericity, trace calcite cement. No shows.
1540	1545	Tr	COAL: as above.
		100	SANDSTONE: quartzose, very light grey, disaggregated, fine to very coarse, clear to dominantly opaque, subangular to rounded, trace angular in coarser grains, trace quartz overgrowths, trace pyrite cement, moderately to poorly sorted, poor to good sphericity, trace calcite cement. No shows.
1545	1550	100	SANDSTONE: as above
1550	1555	100	SANDSTONE: quartzose, very light grey, disaggregated, fine to very coarse, clear to dominantly opaque, subangular to rounded, trace angular in coarser grains, trace quartz overgrowths, trace pyrite cement, moderately to poorly sorted, poor to good sphericity, trace calcite cement. No shows.
1555	1560	80	SANDSTONE: as above – common fracture facets and microcrystalline pyritic, cement.
		20	CLAYSTONE: white, very light grey, soft, amorphous, non-calcareous.
1560	1565	90	SANDSTONE: as above – common fracture facets and microcrystalline pyritic, cement.
		10	CLAYSTONE: white, very light grey, soft, amorphous, non-calcareous.
1565	1570	85	SANDSTONE: as above. Trace lithic grains.
		10	COAL: moderate brown to brownish black, moderately firm to firm, brittle, blocky to sub conchoidal fracture, earthy to sub vitreous lustre, very silty in part.
		5	SILTSTONE: brownish black, dusky brown, firm to hard, sub fissile to sub blocky, carbonaceous with coal laminae, micromicaceous.
1570	1575	100	SANDSTONE: quartzose, very light grey, disaggregated, fine to very coarse and granular, becoming conglomeratic, clear to dominantly opaque, subangular to rounded, minor quartz overgrowths, rare finely crystalline pyrite cement, moderately sorted, poor to good sphericity, trace crystalline dolomite cement. No shows.

Beardie-1 Lithology / Show Descriptions

Interval (m)		%	Lithology / Show Description
From	To		
1575	1582 (Spot)	100	SANDSTONE: quartzose, very light grey, commonly disaggregated, minor hard aggregates, fine to very coarse and granular, becoming conglomeratic, clear to dominantly opaque, subangular to rounded, common strong silica cement, minor crystalline dolomite cement, rare finely crystalline pyrite cement, minor quartz overgrowths, moderately sorted, poor to good sphericity, poor visual porosity. No shows.
1580	1585	60	SANDSTONE: as above.
		40	COAL: brownish black to black, moderately firm to firm, brittle, blocky to sub conchoidal fracture, earthy to sub vitreous lustre, trace silt in part.
1585	1590	90	SANDSTONE: as above, abundant rock flour.
		10	COAL: as above.
1590	1595	95	SANDSTONE: as above, abundant rock flour.
		5	COAL: as above.
1595	1600	95	SANDSTONE: as above, becoming predominantly coarse grained, common broken grains, minor rock flour.
		5	COAL: as above.
1600	1605	100	SANDSTONE: quartzose, very light grey, commonly disaggregated, minor hard aggregates, medium to predominantly coarse, trace very coarse, clear to dominantly opaque, subangular to rounded, minor angular, common strong silica cement, minor crystalline dolomite cement, trace finely crystalline pyrite cement, minor quartz overgrowths, moderately to well sorted, moderate to high sphericity, poor visual porosity. No shows.
1605	1610	100	SANDSTONE: as above, minor rock flour.
1610	1615	100	SANDSTONE: quartzose, very light grey, commonly disaggregated, minor hard aggregates, medium to predominantly coarse, trace very coarse, clear to dominantly opaque, subangular to rounded, minor angular, common strong silica cement, common crystalline dolomite cement with greenish yellow mineral fluorescence, trace finely crystalline pyrite cement, minor quartz overgrowths, moderately to well sorted, moderate to high sphericity, poor visual porosity. No shows.
1615	1620	85	SANDSTONE: as above, minor rock flour. Abundant yellowish green mineral fluorescence.
		5	COAL: as above.
		10	DOLOMITE: dusky brown to dark yellowish brown, hard, earthy to microcrystalline, carbonaceous, silty in part. Tight. Grades to very dolomitic Siltstone in part.
1620	1625	100	COAL: brownish black to black, moderately firm to firm, brittle, blocky to sub conchoidal fracture, earthy to sub vitreous lustre, trace silt in part. Rare rock flour.
1625	1630	60	SANDSTONE: as above, minor rock flour.
		20	COAL: as above
		20	CLAYSTONE: moderate yellowish brown, soft, amorphous, common carbonaceous specks, slightly silty.
		Tr	DOLOMITE: as above.
1630	1635	80	SANDSTONE: as above, minor rock flour.
		20	COAL: as above
		Tr	CLAYSTONE: as above.
1635	1640	80	SANDSTONE: quartzose, very light grey, commonly disaggregated, minor hard aggregates, medium to predominantly coarse, clear to dominantly opaque, angular to subrounded, minor quartz overgrowths, moderately to well sorted, poor sphericity, poor inferred porosity. No shows.
		20	COAL: as above
		Tr	CLAYSTONE: as above.
		Tr	CLAYSTONE: as above.

Beardie-1 Lithology / Show Descriptions

Interval (m)		%	Lithology / Show Description
From	To		
1640	1645	70	COAL: as above
		20	CLAYSTONE: pale yellowish brown to moderate yellowish brown, soft, amorphous, sub fissile, dispersive, common carbonaceous specks, slightly silty.
		10	SANDSTONE: as above, minor rock flour.
1645	1650	70	CLAYSTONE: as above.
		10	COAL: as above.
		20	SANDSTONE: as above.
1650	1655	80	CLAYSTONE: pale yellowish brown to moderate yellowish brown, soft, amorphous, sub fissile, common carbonaceous specks, slightly silty.
		10	COAL: as above.
		10	SANDSTONE: as above, minor rock flour.
1655	1660	70	SANDSTONE: quartzose, very light grey, commonly disaggregated, minor hard aggregates, medium to predominantly very coarse, occasionally granular, clear to dominantly opaque, angular to subrounded, minor quartz overgrowths, rare pyrite cement, trace dolomitic cement, minor calcareous cement, moderate sorting, poor sphericity, good inferred porosity. No shows.
		20	CLAYSTONE: pale yellowish brown to moderate yellowish brown, white, soft, amorphous, sub fissile, very dispersive in part, common carbonaceous specks, slightly silty.
		10	COAL: as above.
1660	1665	100	SANDSTONE: quartzose, very light grey, commonly disaggregated, minor hard aggregates, medium to predominantly very coarse, clear to dominantly opaque, angular to subrounded, minor quartz overgrowths, rare pyrite cement, trace dolomitic cement, minor calcareous cement, moderate sorting, poor sphericity, good inferred porosity. No shows.
		Tr	CLAYSTONE: as above.
1665	1670	70	COAL: brownish black to black, moderately firm to firm, brittle, blocky to sub conchoidal fracture, earthy to sub vitreous lustre, trace silt in part.
		30	SANDSTONE: as above.
1670	1675	60	COAL: as above.
		20	SANDSTONE: as above.
		30	CLAYSTONE: pale yellowish brown to moderate yellowish brown, white, soft, amorphous, sub fissile, very dispersive in part, common carbonaceous specks, silty – grading to carbonaceous, argillaceous Siltstone.
1675	1680	50	SANDSTONE: as above. Common rock flour?
		50	CLAYSTONE: as above.
1680	1685	70	SANDSTONE: as above. Common rock flour?
		30	CLAYSTONE: as above.
1685	1690	90	SANDSTONE: as above. Common rock flour?
		10	CLAYSTONE: as above.
		Tr	COAL: as above.
1690	1695	60	SANDSTONE: quartzose, very light grey, commonly disaggregated, medium to coarse, clear to dominantly opaque, angular to subrounded, minor quartz overgrowths, rare pyrite cement, minor calcareous cement, moderate sorting, poor sphericity, good inferred porosity. No shows.
		40	COAL: as above.
		50	SANDSTONE: as above.
1695	1700	30	CLAYSTONE: as above.
		20	COAL: as above.
		50	SANDSTONE: as above.
1700	1705	40	CLAYSTONE: as above.
		10	COAL: as above.

Beardie-1 Lithology / Show Descriptions

Interval (m)		%	Lithology / Show Description
From	To		
1705	1710	50	SANDSTONE: quartzose, very light grey, commonly disaggregated, medium to coarse, clear to dominantly opaque, angular to subrounded, minor quartz overgrowths, rare pyrite cement, minor calcareous cement, moderate sorting, poor sphericity, good inferred porosity. No shows.
		40	CLAYSTONE: pale yellowish brown to moderate yellowish brown, white, soft, amorphous, sub fissile, very dispersive in part, common carbonaceous specks, silty – grading to carbonaceous, argillaceous Siltstone.
		10	COAL: brownish black to black, moderately firm to firm, brittle, blocky to sub conchoidal fracture, earthy to sub vitreous lustre, trace silt in part.
1710	1715	60	COAL: brownish black to black, moderately firm to firm, brittle, blocky to sub conchoidal fracture, earthy to sub vitreous lustre, trace silt in part.
		20	SANDSTONE: quartzose, very light grey, commonly disaggregated, medium to coarse, clear to dominantly opaque, angular to subrounded, minor quartz overgrowths, rare pyrite cement, minor calcareous cement, moderate sorting, poor sphericity, good inferred porosity. No shows.
		20	CLAYSTONE: pale yellowish brown to moderate yellowish brown, white, soft, amorphous, sub fissile, very dispersive in part, common carbonaceous specks, silty – grading to carbonaceous, argillaceous Siltstone.
1715	1720	60	SANDSTONE: as above.
		30	CLAYSTONE: as above.
		10	COAL: as above.
1720	1725	65	SANDSTONE: as above, trace nodular pyrite.
		30	CLAYSTONE: as above.
		5	COAL: as above.
1725	1730	60	SANDSTONE: as above, trace nodular pyrite.
		40	CLAYSTONE: as above.
1730	1735	65	SANDSTONE: as above, trace nodular pyrite.
		30	CLAYSTONE: as above.
		5	COAL: as above.
1735	1740	65	SANDSTONE: as above, trace nodular pyrite.
		30	CLAYSTONE: as above.
		5	COAL: as above, trace pyrite.
1740	1745	90	SANDSTONE: quartzose, very light grey, commonly disaggregated, medium to coarse, clear to dominantly opaque, angular to subrounded, minor quartz overgrowths, rare pyrite cement, minor calcareous cement, trace nodular pyrite, moderate sorting, poor sphericity, good inferred porosity. No shows.
		10	CLAYSTONE: pale yellowish brown to moderate yellowish brown, white, soft, amorphous, sub fissile, very dispersive in part, common carbonaceous specks, silty – grading to carbonaceous, argillaceous Siltstone.
1745	1750	100	SANDSTONE: quartzose, very light grey, commonly disaggregated, predominantly medium, minor coarse, clear to dominantly opaque, angular to subrounded, minor quartz overgrowths, rare pyrite cement, minor calcareous cement, moderately to well sorted, low sphericity, good inferred porosity. No shows.
1750	1755	100	SANDSTONE: as above, trace nodular pyrite.
1755	1760	Tr	COAL: as above.
		90	SANDSTONE: as above, trace nodular pyrite.
		10	CLAYSTONE: as above.
		Tr	COAL: as above.

Beardie-1 Lithology / Show Descriptions

Interval (m)		% Lithology / Show Description
From	To	
1760	1765	80 SANDSTONE: quartzose, very light grey, commonly disaggregated, predominantly medium, minor coarse, clear to dominantly opaque, angular to subrounded, minor quartz overgrowths, rare pyrite cement, minor calcareous cement, trace nodular pyrite, moderately to well sorted, low sphericity, good inferred porosity. No shows.
		15 CLAYSTONE: pale yellowish brown to moderate yellowish brown, white, soft, amorphous, sub fissile, very dispersive in part, common carbonaceous specks, silty – grading to carbonaceous, argillaceous Siltstone.
		5 COAL: brownish black to black, moderately firm to firm, brittle, blocky to sub conchoidal fracture, earthy to sub vitreous lustre, trace silt in part.
1765	1770	90 SANDSTONE: as above.
		10 CLAYSTONE: as above.
		Tr COAL: as above.
1770	1775	100 SANDSTONE: as above.
		Tr COAL: as above.
1775	1780	100 SANDSTONE: as above.
		Tr COAL: as above.
1780	1785	90 SANDSTONE: quartzose, very light grey, commonly disaggregated, medium to coarse, clear to dominantly opaque, angular to subrounded, minor quartz overgrowths, rare pyrite cement, minor calcareous cement, trace nodular pyrite, common rock flour, moderately to well sorted, low sphericity, good inferred porosity. No shows.
		10 CLAYSTONE: pale yellowish brown to moderate yellowish brown, white, soft, amorphous, sub fissile, very dispersive in part, common carbonaceous specks, silty – grading to carbonaceous, argillaceous Siltstone.
		COAL: brownish black to black, moderately firm to firm, brittle, blocky to sub conchoidal fracture, earthy to sub vitreous lustre, trace disseminated pyrite, trace very fine quartz laminae, trace silt in part.
1785	1790	10 SANDSTONE: as above.
		Tr CLAYSTONE: as above.
		90 SANDSTONE: as above.
1790	1795	10 COAL: as above.
		95 SANDSTONE: as above.
1795	1800	5 COAL: as above.
		100 SANDSTONE: as above.
1800	1805	Tr COAL: as above.
		100 SANDSTONE: as above.
1805	1810	Tr COAL: as above.
		60 SANDSTONE: quartzose, very light grey, commonly disaggregated, medium to coarse, clear to dominantly opaque, angular to subrounded, minor quartz overgrowths, rare pyrite cement, minor calcareous cement, trace nodular pyrite, common rock flour, moderately to well sorted, low sphericity, good inferred porosity. No shows.
1810	1815	40 CLAYSTONE: pale yellowish brown to moderate yellowish brown, white, soft, amorphous, sub fissile, very dispersive in part, common carbonaceous specks, silty – grading to carbonaceous, argillaceous Siltstone.
		Tr COAL: as above.
		70 SANDSTONE: as above.
1815	1820	30 CLAYSTONE: as above.
		Tr COAL: as above.
		60 SANDSTONE: as above.
1820	1825	40 CLAYSTONE: as above.
		Tr COAL: as above.

Beardie-1 Lithology / Show Descriptions

Interval (m)		%	Lithology / Show Description
From	To		
1825	1830	60	CLAYSTONE: pale yellowish brown to moderate yellowish brown, white, soft, sticky, amorphous, sub fissile, very dispersive in part, common carbonaceous specks, silty – grading to carbonaceous, argillaceous Siltstone.
		40	SANDSTONE: quartzose, very light grey, commonly disaggregated, predominantly medium, minor coarse, clear to dominantly opaque, angular to subrounded, minor quartz overgrowths, rare pyrite cement, trace nodular pyrite, moderately to well sorted, low sphericity, good inferred porosity. No shows.
1830	1835	60	SANDSTONE: as above.
		40	CLAYSTONE: as above.
1835	1840	70	CLAYSTONE: as above.
		30	SANDSTONE: as above.
		Tr	COAL: brownish black to black, moderately firm to firm, brittle, blocky to sub conchoidal fracture, earthy to sub vitreous lustre, trace disseminated pyrite, trace very fine quartz laminae, trace silt in part.
1840	1845	80	SANDSTONE: quartzose, very light grey, commonly disaggregated, predominantly medium, minor coarse, clear to dominantly opaque, angular to subrounded, minor quartz overgrowths, rare pyrite cement, trace nodular pyrite, moderately to well sorted, low sphericity, good inferred porosity. No shows.
		20	CLAYSTONE: pale yellowish brown to moderate yellowish brown, white, soft, sticky, amorphous, sub fissile, very dispersive in part, common carbonaceous specks, silty – grading to carbonaceous, argillaceous Siltstone.
		Tr	COAL: brownish black to black, moderately firm to firm, brittle, blocky to sub conchoidal fracture, earthy to sub vitreous lustre, trace disseminated pyrite, trace very fine quartz laminae, trace silt in part.
1845	1850	90	SANDSTONE: as above.
		10	CLAYSTONE: as above.
1850	1855	70	SANDSTONE: as above.
		20	CLAYSTONE: as above.
		10	COAL: as above.
1855	1860	90	SANDSTONE: quartzose, very light grey, commonly disaggregated, predominantly medium, minor coarse, clear to dominantly opaque, angular to subrounded, minor quartz overgrowths, rare pyrite cement, trace nodular pyrite, moderately to well sorted, low sphericity, good inferred porosity. No shows.
		10	CLAYSTONE: as above.
1860	1865	90	SANDSTONE: as above.
		10	CLAYSTONE: as above.
1865	1870	60	SANDSTONE: as above.
		40	CLAYSTONE: as above.
1870	1875	70	SANDSTONE: quartzose, very light grey, commonly disaggregated, medium to predominantly coarse grained, clear to dominantly opaque, angular to subrounded, minor quartz overgrowths, rare pyrite cement, trace nodular pyrite, moderately to well sorted, low sphericity, good inferred porosity. No shows.
		30	CLAYSTONE: pale yellowish brown to very light grey, white, soft, sticky, amorphous, very dispersive in part, trace to common carbonaceous specks, silty – grading in small part to carbonaceous, argillaceous Siltstone.
1875	1880	60	SANDSTONE: as above.
		40	CLAYSTONE: as above.
1880	1885	80	CLAYSTONE: as above.
		20	SANDSTONE: as above.

Beardie-1 Lithology / Show Descriptions

Interval (m)		%	Lithology / Show Description
From	To		
1885	1890	80	CLAYSTONE: as above.
		10	CLAYSTONE: light to medium grey, firm to hard, sub fissile, very pyritic, slightly silty.
		10	SANDSTONE: as above.
1890	1895	100	CLAYSTONE: as above. Tr Claystone: light to medium grey as above.
1895	1900	80	CLAYSTONE: as above. Tr Claystone: light to medium grey as above.
		20	SANDSTONE: as above.
1900	1905	80	CLAYSTONE: as above. Tr Claystone: light to medium grey as above.
		20	SANDSTONE: as above.

Reached TD 1905m MDRT on the 3rd August, 2002 at 2055 hrs.

APPENDIX 2

APPENDIX 2

SIDEWALL CORE DESCRIPTIONS

Beardie-1 Sidewall Core Descriptions

No	Depth (m)	Rec. (mm)	B/R	Description
1	1887.0	26		CLAYSTONE: very light grey to light grey, soft, sticky, amorphous, very dispersive in part, common carbonaceous specks and blebs, slightly silty.
2	1870.0	27		CLAYSTONE: very light grey to light grey, soft, sticky, amorphous, very dispersive in part, common pyritic specks, slightly silty.
3	1845.0	20		CLAYSTONE: very light grey to light grey, soft, sticky, amorphous, very dispersive in part, common carbonaceous laminae &/or 'dead oil'.
4	1795.5	30		COAL: brownish black to black, moderately firm to firm, brittle, blocky to sub conchoidal fracture, earthy to sub vitreous lustre, common microcrystalline nodular pyrite.
5	1793.0	27		CLAYSTONE: light grey, soft, sticky, amorphous, dispersive in part, common microcrystalline nodular pyrite, slightly silty.
6	1730.0	Misfire		
7	1717.0	33		SANDSTONE: quartzose, very light grey, very soft, medium to coarse, clear to dominantly opaque, angular to subangular, moderate sorting, very poor sphericity, minor quartz overgrowths, minor argillaceous cement, good visible porosity. Rare spotty oil staining? Dull, even gold fluorescence with instant, blue white cloudy cut and fluorescent, blue white residual ring.
8	1706.0	35		COAL: brownish black to black, moderately firm to firm, brittle, blocky to sub conchoidal fracture, earthy to sub vitreous lustre.
9	1696.0	Misfire		
10	1689.0	30		SANDSTONE: quartzose, very light grey, very soft, fine to medium, clear to dominantly opaque, angular to subangular, well sorted, very poor sphericity, common argillaceous cement, good visible porosity. Rare spotty oil staining? Dull, even gold fluorescence with slow streaming, blue white cut and fluorescent, white residual ring.
11	1687.5	25		SILTSTONE: pale yellowish brown to dark yellowish brown, white laminae, soft, sub fissile, very argillaceous, dispersive in part, trace carbonaceous specks, grading to silty Claystone. Very faint dull, even gold fluorescence with very slow streaming, blue white cut and faint, fluorescent, bluish white residual ring.
12	1684.0	Misfire		
13	1660.0	25		SANDSTONE: quartzose, very light grey, very soft, fine to medium, clear to dominantly opaque, angular to subangular, well sorted, poor sphericity, common argillaceous cement, good visible porosity.
14	1657.0	30		CLAYSTONE: laminated pale yellowish brown and dark yellowish brown, soft, amorphous, slightly dispersive, sub fissile, slightly silty.
15	1597.0	Misfire		
16	1544.0	20		CLAYSTONE: dark yellowish brown, soft, amorphous, common carbonaceous specks, rare disseminated pyrite, slightly silty.
17	1504.0	20		SILTSTONE: pale yellowish brown to dark yellowish brown, soft, common argillaceous matrix, trace very fine quartz, trace carbonaceous specks.
18	1491.0	Misfire		

Beardie-1 Sidewall Core Descriptions

No	Depth (m)	Rec. (mm)	B/R	Description
19	1489.0	25		SILTSTONE: (95%) laminated light brownish grey, dark yellowish brown, soft, common argillaceous matrix, trace very fine quartz, trace carbonaceous specks. COAL: (5%) brownish black to black, moderately firm to firm, brittle, blocky to sub conchoidal fracture, earthy to sub vitreous lustre. Occurs as lenses and laminae.
20	1468.0	35		SILTSTONE: dark yellowish brown, soft, common argillaceous matrix, trace micromica.
21	1424.0	Misfire		
22	1422.0	33		SILTSTONE: dark yellowish brown, soft, common argillaceous matrix, trace micromica.
23	1419.0	20		SANDSTONE: quartzose, very light grey, soft and friable, very fine grained, clear to dominantly opaque grains, subangular to sub rounded, well sorted, moderate sphericity, trace microcrystalline pyrite cement, trace light brownish grey argillaceous matrix. Good visible porosity. No shows.
24	1416.0	35		SANDSTONE: quartzose, very light grey, very soft, fine grained, clear to dominantly opaque, subangular to sub rounded, well sorted, good sphericity, trace argillaceous cement. Good visible porosity. Strong petroliferous odour; moderately bright, even, greenish blue fluorescence with a slow streaming, blue white cut and dull blue white residual ring.
25	1414.5	35		SANDSTONE: quartzose, very light grey, very soft, fine grained, clear to dominantly opaque, subangular to sub rounded, well sorted, good sphericity, trace argillaceous and calcareous cements. Good visible porosity. Strong petroliferous odour; dull, even, greenish gold fluorescence with a very slow streaming, blue cut and dull blue white residual ring.
26	1412.5	25		SANDSTONE: quartzose, very light grey, very soft, fine grained, clear to dominantly opaque, subangular to sub rounded, well sorted, good sphericity, trace argillaceous and calcareous cements. Good visible porosity. Strong petroliferous odour; dull, even, greenish gold fluorescence with a very slow streaming, white cut and dull yellowish ring.
27	1411.0	30		SANDSTONE: quartzose, very light grey, very soft, fine to coarse grained, predominantly medium, clear to dominantly opaque, angular to subangular, poorly sorted, fair sphericity, common argillaceous cement. Fair visible porosity. Strong petroliferous odour; moderately bright, even, greenish blue fluorescence with a slow streaming, blue white cut and moderately bright whitish blue residual ring. No residual ring visible under white light.
28	1410.0	35		SILTSTONE: (70%) pale yellowish brown, soft, common argillaceous matrix, trace micromica. CLAYSTONE: (30%) dark yellowish brown, soft, amorphous, slightly dispersive, sub fissile, slightly silty.
29	1382.0	35		Laminated SILTSTONE: pale yellowish brown, soft, common argillaceous matrix, trace micromica, slightly calcareous, trace carbonaceous specks, trace finely disseminated pyrite – grades to very silty Sandstone. CLAYSTONE: dark yellowish brown, soft, amorphous, slightly dispersive, sub fissile, slightly silty.
30	1369.0	35		SANDSTONE: quartzose, very light grey, very soft, friable, fine to coarse, rare coarse, clear to dominantly opaque, angular to sub

Beardie-1 Sidewall Core Descriptions

No	Depth (m)	Rec. (mm)	B/R	Description
				rounded, poorly sorted, poor to fair sphericity, common argillaceous cement. Good visible porosity. No shows.
31	1366.5	40		SANDSTONE: quartzose, very light grey, very soft, friable, fine to medium grained, clear to dominantly opaque, angular to sub angular, well sorted, poor sphericity, common argillaceous cement. Trace quartz overgrowths, good visible porosity. No shows.
32	1354.0	30		SILTSTONE: light brownish grey to brownish grey, firm, common argillaceous matrix, minor very finely disseminated pyrite, minor carbonaceous specks. CLAYSTONE: dark yellowish brown, soft, amorphous, slightly dispersive, sub fissile, silty – grading to very argillaceous Siltstone in part.
33	1347.0	Misfire		
34	1320.5	20		SANDSTONE: quartzose, very light grey, loose and friable, fine to medium, clear to dominantly opaque, angular to sub rounded, well sorted, poor to occasionally good sphericity, common white argillaceous matrix, trace black lithic grains. Very good visible porosity. No show.
35	1315.0	30		Laminae of COAL: brownish black, moderately firm, brittle, fissile fracture, sub vitreous lustre. and CLAYSTONE: dark yellowish brown, firm, sub fissile, slightly dispersive.
36	1310.0	Misfire		
37	1289.0	25		SANDSTONE: quartzose, very light to medium grey, loose and friable, fine to very coarse, clear to dominantly opaque, angular to subrounded, poorly sorted, poor to occasionally good sphericity, minor microcrystalline pyrite cement, common light grey argillaceous matrix. Good visible porosity. No show.
38	1288.0	20		SANDSTONE: quartzose, brownish grey, firm, very fine to very coarse, predominantly very fine to fine grained, clear to dominantly opaque, angular to subrounded, poorly sorted, poor to occasionally good sphericity, common silt and minor argillaceous matrix. Poor visible porosity. No show. Grades to arenaceous Siltstone. Minor laminae of Claystone as above.
39	1284.0	Misfire		
40	1276.0	30		SANDSTONE: quartzose, light grey, soft and friable, fine grained, clear to dominantly opaque, angular to subangular, well sorted, poor to good, sphericity, minor argillaceous matrix, rare pyrite cement. Good visible porosity. No show.
41	1273.0	20		SANDSTONE: quartzose, very light grey, friable, very fine to fine grained, clear to dominantly opaque, subangular to subrounded, well sorted, rare to minor microcrystalline pyrite cement, common white argillaceous cement, rare dolomitic cement. Good visible porosity. No show.
42	1262.5	Misfire		
43	1258.0	35		SANDSTONE: quartzose, very light grey, friable, fine grained, clear to dominantly opaque, subangular to subrounded, well sorted, rare to minor microcrystalline pyrite cement, rare, white argillaceous cement. Good visible porosity. Strong petroliferous odour; moderately bright, even, greenish yellow fluorescence with a slow streaming, yellowish white cut, bluish white residual ring, no residual ring visible under white light.
44	1252.0	Misfire		

Beardie-1 Sidewall Core Descriptions

No	Depth (m)	Rec. (mm)	B/R	Description
45	1250.5	Misfire		
46	1244.0	Misfire		
47	1226.0	25		SILTSTONE: light grey and pale yellowish brown, soft, common argillaceous matrix, common microcrystalline pyritic blebs, trace carbonaceous specks and wisps, trace 'dead oil' specks, slightly dolomitic, trace fine quartz grains.
48	1223.0	Misfire		
49	1218.0	25		SANDSTONE: quartzose, olive grey, firm, very fine to fine grained, trace very coarse, clear to dominantly opaque, angular to subangular, well sorted, common disseminated, microcrystalline pyrite cement, minor glauconite grains. Fair visible porosity. No show.
50	1212.0	20		SANDSTONE: quartzose, pale yellowish brown to light brownish grey, firm and friable, very fine to fine grained, occasionally medium, opaque to dominantly clear, subangular to subrounded, well sorted, moderate sphericity, minor microcrystalline pyrite cement, minor argillaceous matrix. Good visible porosity. No show.
51	1207.0	Misfire		
52	1204.0	33		SANDSTONE: quartzose, very light grey, soft to firm, disaggregated, medium to granular, clear to dominantly opaque, subangular to rounded, moderate sorting, poor to occasionally good sphericity. Common microcrystalline pyrite cement and rare dolomitic cement. Good visible porosity. No show.
53	1198.0	40		SANDSTONE: quartzose, very light grey, soft to firm, disaggregated, medium to granular, clear to dominantly opaque, subangular to rounded, poor sorting, moderate sphericity. Abundant microcrystalline pyrite cement and glauconite as grains and cement. Good visible porosity. Dull, even, gold fluorescence with a very slow streaming, blue cut. Bright whitish blue residual ring. No visible ring under white light.
54	1194.0	40		CLAYSTONE: brownish grey to olive black, firm, sub blocky, trace disseminated pyrite, abundant green and dark green medium to coarse grains of glauconite and glauconitic clay, slightly calcareous, trace micromica, rare quartz grains.
55	1186.0	28		SILTSTONE: olive grey, firm, amorphous to sub blocky, trace disseminated pyrite laminae, minor green and dark green fine to coarse grains of glauconite and glauconitic clay, common microfossil material – partly replaced by glauconite, calcareous. Grades in part to a silty Claystone.
56	1160.0	30		CLAYSTONE: olive grey, firm, amorphous to massive, minor disseminated pyrite, calcareous.
57	1140.0	30		CALCISILTITE: olive grey, mottled white, firm, massive, argillaceous, trace disseminated pyrite laminae, minor green glauconitic clay, common microfossil material – partly replaced by glauconite, calcareous. Trace coarse, white quartz grains.
58	1091.0	23		SANDSTONE: quartzose, olive grey, soft to disaggregated, medium to very coarse grained, occasionally granular, clear to dominantly frosted, angular to rounded, good sphericity, trace microcrystalline pyrite cement. Common white calcite matrix cement. Good visible porosity. No show.

Beardie-1 Sidewall Core Descriptions

No	Depth (m)	Rec. (mm)	B/R	Description
59	1080.0	30		SANDSTONE: quartzose, olive grey, soft to disaggregated, medium to very coarse grained, occasionally granular, clear to dominantly frosted, angular to rounded, good sphericity, rare glauconite grains and glauconitic clay, minor microcrystalline pyrite cement, common white calcite matrix cement. Trace lithic grains. Good visible porosity. No show.
60	1070.0	25		ARGILLACEOUS CALCISILTITE: light olive grey, soft to firm, massive, common argillaceous matrix, trace crystalline calcite, trace carbonaceous specks, trace forams, rare glauconite. Grades to very calcareous Claystone in part.

913713 051

APPENDIX 3

APPENDIX 3

MDT RESULTS

This is Page Number **913713 053X**

This is an enclosure indicator page.

The page that follows this page is an uncatalogued
fold-out (or A4 colour) with page number:

913713 053Y

and is enclosed within the document **PE913713** at
this page.

EALP - WELL MDT FLUID SAMPLE DATA

Well:			BEARDIE - 1							
A. Sample Identification										
Run/seat number	##	1								
Sample depth	md m rkb	1689								
Prefest volume	cc	20 ccs								
Chamber size	cc/litre/gallon	450 ccs								
Chamber serial number	#									
Probe type		Large								
Choke size		n/a								
B. Sampling History										
Date	dd/mm/yy	5/08/02								
Initial hydrostatic	psia	2869.6								
Tool Set	hh:mm	13:09								
Pretest start	hh:mm	13:11								
Initial formation pressure (pre)	psia	2344.6								
Pretest end	hh:mm	13:14								
Pretest duration	hh:mm	0:03								
Pumpout start	hh:mm	13:14								
Pumpout end	hh:mm	14:10								
Pumpout duration	hh:mm	0:56								
Pumpout volume	litres	35.1								
OFA indication	colour	blue								
Interpreted fluid at OFA	-	water								
Maximum resistivity at probe	ohm-m	0.2655								
Chamber open	hh:mm									
Minimum sampling pressure	psia									
Final formation pressure	psia									
Seal chamber	hh:mm									
Chamber fill time	hh:mm									
Tool retract	hh:mm									
Final hydrostatic	psia									
Total time	hh:mm									
C. Sample Downhole Temperature And Resistivity										
At sample depth (AMS)	degC									
Rm@sample depth (AMS)	ohm-m									
D. Sample Recovery At Surface										
Surface opening pressure	psig									
Volume gas	cuff									
Volume oil/condensate	litres									
Volume water/filtrate	litres									
E. Sample Properties Measured On-Site										
Gas via cd	C1	Mole %	0	0	0	0	0	0	0	0
	C2	Mole %	0	0	0	0	0	0	0	0
	C3	Mole %	0	0	0	0	0	0	0	0
	C4	Mole %	0	0	0	0	0	0	0	0
	C5	Mole %	0	0	0	0	0	0	0	0
	C6+	Mole %								
	CO2	Mole %	0	0	0	0	0	0	0	0
	H2S	Mole %	0	0	0	0	0	0	0	0
Oil/Cond	API @ degC	degrees	0	0	0	0	0	0	0	0
	Colour									
	Fluorescence									
	GOR or CGR	cuff/bbl or mmscf/bbl	0	0	0	0	0	0	0	0
	Pour point	degC	0	0	0	0	0	0	0	0
Water/Filt	Rmud @ degC	ohm-m@degC	0	0	0	0	0	0	0	0
	K+ ion calculated	ppm	0	0	0	0	0	0	0	0
	Chlorides titrated	ppm	0	0	0	0	0	0	0	0
	Tritium	DPM								
	pH		0	0	0	0	0	0	0	0
	Type									
F. Mud Filtrate Properties										
Rmud @ degC	ohm-m@degC		0	0	0	0	0	0	0	0
K+ ion calculated from KCL	ppm		0	0	0	0	0	0	0	0
Chlorides titrated	ppm		0	0	0	0	0	0	0	0
pH			0	0	0	0	0	0	0	0
Tritium	DPM									
G. General Calibration										
Reported mud weight	ppg		0	0	0	0	0	0	0	0
Calculated hydrostatic	psia		G	G	G	G	G	G	G	G
H. Remarks and Comments										
General	Sample Specific	Sample Specific	Sample Specific	Sample Specific	Sample Specific	Sample Specific	Sample Specific	Sample Specific	Sample Specific	Sample Specific

Note: Schlumbergers one gallon chamber (MRSC-BB-090) was transferred to ACS cylinder number (817398) From: 2925.5m

EALP - WELL MDT FLUID SAMPLE DATA

Well:		BEARDIE - 1							
A. Sample Identification									
Run/seat number	#/#	1							
Sample depth	md m rkb	1689							
Prefest volume	cc	20 ccs							
Chamber size	cc/litre/gallon	450 ccs							
Chamber serial number	#								
Probe type		Large							
Choke size		n/a							
B. Sampling History									
Date	dd/mm/yy	5/08/02							
Initial hydrostatic	psia	2869.6							
Tool Set	hh:mm	13:09							
Pretest start	hh:mm	13:11							
Initial formation pressure (pr	psia	2344.6							
Pretest end	hh:mm	13:14							
Pretest duration	hh:mm	0:03							
Pumpout start	hh:mm	13:14							
Pumpout end	hh:mm	14:10							
Pumpout duration	hh:mm	0:56							
Pumpout volume	litres	35.1							
OFA indication	colour	blue							
Interpreted fluid at OFA	-	water							
Maximum resistivity at probe	ohm-m	0.2655							
Chamber open	hh:mm								
Minimum sampling pressure	psia								
Final formation pressure	psia								
Seal chamber	hh:mm								
Chamber fill time	hh:mm								
Tool retract	hh:mm								
Final hydrostatic	psia								
Total time	hh:mm								
C. Sample Downhole Temperature And Resistivity									
At sample depth (AMS)	degC								
Rm@sample depth (AMS)	ohm-m								
D. Sample Recovery At Surface									
Surface opening pressure	psig								
Volume gas	cuff								
Volume oil/condensate	litres								
Volume water/filtrate	litres								
E. Sample Properties Measured On-Site									
Gas via ch	C1	Mole %	0	0	0	0	0	0	0
	C2	Mole %	0	0	0	0	0	0	0
	C3	Mole %	0	0	0	0	0	0	0
	C4	Mole %	0	0	0	0	0	0	0
	C5	Mole %	0	0	0	0	0	0	0
	C6+	Mole %							
	CO2	Mole %	0	0	0	0	0	0	0
	H2S	Mole %	0	0	0	0	0	0	0
Oil/Cond	API @ degC	degrees	0	0	0	0	0	0	0
	Colour								
	Fluorescencé								
	GOR or CGR	cuff/bbl or mmsct/bbl	0	0	0	0	0	0	0
	Pour point	degC	0	0	0	0	0	0	0
Water/Filt	Rmud @ degC	ohm-m@degC	0	0	0	0	0	0	0
	K+ ion calculated	ppm	0	0	0	0	0	0	0
	Chlorides titrated	ppm	0	0	0	0	0	0	0
	Tritium	DPM							
	pH		0	0	0	0	0	0	0
	Type								
F. Mud Filtrate Properties									
Rmud @ degC	ohm-m@degC		0	0	0	0	0	0	0
K+ ion calculated from KCL	ppm		0	0	0	0	0	0	0
Chlorides titrated	ppm		0	0	0	0	0	0	0
pH			0	0	0	0	0	0	0
Tritium	DPM								
G. General Calibration									
Reported mud weight	ppg		0	0	0	0	0	0	0
Calculated hydrostatic	psia		G	G	G	G	G	G	G
H. Remarks and Comments									
General	Sample Specific	Sample Specific	Sample Specific	Sample Specific	Sample Specific	Sample Specific	Sample Specific	Sample Specific	Sample Specific

Note: Schlumbergers one gallon chamber (MRSC-BB-090) was transfered to ACS cylinder number (817398) From: 2925.5m

APPENDIX

4

913713 058

APPENDIX 4

MUDLOGGING REPORT



INTEQ

END OF WELL REPORT

ESSO AUSTRALIA PTY LTD

BEARDIE - 1

JULY - AUGUST 2002

by

BAKER HUGHES INTEQ

The information, interpretations, recommendations, or opinions contained herein are advisory only and may be rejected. Consultant does not warrant their accuracy or correctness. Nothing contained herein shall be deemed to be inconsistent with, nor expand, modify or alter Consultant's obligation of performance as provided for in a written agreement between the parties, or, if none, in Consultant's most recent price list.

Esso Australia Pty Ltd: Beardie-1**Final Well Report**

Section 1	Operations Summary		
	1-1	Introduction	
	1-2	Well and rig information	
Section 2	Drilling and Engineering		
	2-1	Bit Run Summaries	
	2-2	Casing and Cement Summaries	
Section 3	Geology and Shows		
	3-1	Geology Summary and Shows	
	3-2	Sample Distribution	
Section 4	Pressure Evaluation		
	4-1	Pore Pressure Evaluation	
	4-2	Fracture Pressure Evaluation	
Tables	1	Bit Run Summary	
	2	Bit Hydraulics Summary	
	3	Survey Data Summary	
	4	Time vs. Depth Curve	
Appendices	1	Formation Evaluation Log	1: 500
	2	Drilling Data Plot	1:1000
	3	Pressure Data Plot	1:1000
	4	Pressure Summary Plot	
	5	Gas Ratio Plot	1: 500

913713 061

Section 1

Operations Summary

1. Operations Summary

1.1 Introduction

Baker Hughes INTEQ Mudlogging provided formation evaluation, drill monitoring and pressure evaluation services for Beardie-1 from spud until P&A. Data was processed and stored using Drillbyte V.2.3.1 software. All depths in this report unless otherwise stated refer to mMDRT - measured distance in metres from the rig's rotary table.

Beardie-1 was planned as a 1905mMD vertical hole to test the oil potential of the Intra Latrobe Group sandstones, with an option to deepen the well to 3075mMD in a success case.

The well was spudded at 17:00 hours on 26 July 2002, drilling the 36" hole with a 26" bit with 36" hole opener from the seabed at 76.2m to 122.5m using seawater and high viscosity prehydrated gel (PHG) sweeps. The 30" conductor casing was run with the casing shoe set at 122.0m.

The 17.5" hole was then drilled riserless with rates of penetration averaging 50m/hr, using seawater with guar gum sweeps every joint and hi-vis sweeps every stand to the section TD of 863m. The 13.375" casing was run smoothly with the shoe at 849.1m. The BOPs were landed and tested as per programme.

Drilling of the 12.25" hole section commenced with a 12.25" Reed Hycalog DSX195DGNW PDC bit, made up on a rotary bottom hole assembly with MWD and ARC tools. After running and testing BOPs and marine riser it was run in the hole, tagging cement at 820m. The hole was displaced to 8.9ppg KCl/PHPA/Glycol mud while drilling out cement, the shoe track and the casing shoe at 849.1m. Three metres of new formation, from 863m to 866m was drilled before circulating bottoms up and pulling the bit back into the casing shoe and performing a Pressure Integrity Test (PIT). A surface pressure of 838psi exerted on the formation with 8.9ppg mud yielded an Equivalent Mud Weight (EMW) of 14.73ppg. Drilling resumed from 866m to 913m. Drilling was halted briefly to change out a backed out saver sub on the TDS. Drilling resumed from 913m and the mud weight was gradually increased to 9.5ppg, and then naturally increased to 9.8ppg by the end of the bit run. A maximum gas of 1.12% was seen at 1405m. The hole was drilled down to 1579m where it was decided to pull out of hole due to slow rates of penetration. Two tight spots were seen on the trip out, both giving 20klbs of overpull at 1282m and 1098m. No other hole problems were noted on the trip out.

After the bit trip drilling of the 12.25" hole section continued with a Reed EHP51HKPRDH tricone insert bit, made up on a rotary drilling assembly with in-string MWD & CDR tools. It was run in the hole, tagging fill at 1572m from where the bit was washed and reamed down to bottom at 1579m. New 12.25" hole was drilled from 1579m to TD at 1905m. A maximum gas of 4.67% was seen at 1675m. On reaching TD a 100bbl Hi-Vis pill was pumped and bottoms up circulated, before conducting a flow check (static) and pulling out of hole for a wiper trip. After 3 stands had been pulled tight hole was encountered with 60K overpull. The drillstring was made up to the top drive and circulation broken to condition the hole. The string was then pumped and rotated out of the hole to the 13.375" shoe and then run back to bottom to complete the wiper trip. 6m of fill was encountered on the trip back to bottom. Bottoms up was circulated twice, large chunks of coal were seen at the shakers, this is suspected as the cause of the hole fill. After a flowcheck the bit was pulled out of hole to run wireline log. After a full suite of wireline logs was run, Beardie-1 was plugged and abandoned. The Ocean Bounty was towed off location on the 10th of August 2002.

1.2 Well and Rig Information

Well Name: Beardie-1

Well Type: Wildcat Exploration

Operator: ESSO Australia Pty Ltd.

Location: Gippsland Basin, Offshore Victoria, Australia

Block: VIC/L2

Final Coordinates: Latitude 38° 15' 16.214" S
Longitude 147° 48' 24.643" E

Rig: Ocean Bounty

Type: Semi-submersible MODU

Rig Floor - Seabed: 76.2 mMDRT

Rig Floor - MSL 25 m

Spud Date: 26 July 2002

Total Depth: 1905 mMDRT

Status: Plugged & Abandoned

Baker Hughes INTEQ: Data Engineers: Jeff Wilson
Jamie McLeod
Rommel Tadiar

Logging Geologists: Elaine Spence
Tomasz Zelski
Trent Liang
Amanda Henson

913713 064

Section 2

Drilling and Engineering

2.1

2.1 Bit Run Summaries**36" Phase: 26 July 2002****Bit Run 1 Summary**

Bit Number	NB 1
Bit Size	26" / 36" hole opener
Bit Type	Security S3SJ4
S/N	SCR 668369
Jets	4x20 (H-O 5x13)
Depth In	76.2m
Depth Out	122.5m
Metres Drilled	46.3
Drilling Hours	1.0
TBR, krevs	6.2
Circulating Hours	2.0
Average ROP, m/hr	47.3
API Condition	2-2-NO-A-E-I-NO-TD(H/O)

Drilling Parameters

WOB, tonnes	3.3	-	8.7
RPM	64	-	83
Torque kft-lbs.	0.9	-	5.6
Pump Pressure, psi	160	-	952
Flow In, gpm	508	-	1083

Mud System

Seawater & hi-viscosity Gel Sweeps	8.6 ppg
------------------------------------	---------

Lithology

Returns to seabed.

Drilling Summary

After running anchors, a 26" roller bit with 36" hole opener tagged the seabed at 76.2m. Beardie-1 was spudded at 17:00hrs on 26 July 2002. The section was drilled on heavy weight drill pipe using seawater, with 50bbls hi-vis prehydrated gel (PHG) sweeps pumped every 15 metres. At section TD of 122.5m, a 100bbls Guar gum pill was swept around before displacing the hole with 400bbls hi-vis pill. A wiper trip to 84 metres was performed. The bit was then run back to bottom and the hole was displaced with a 400bbls hi-vis pill. The bit was pulled to surface to run the 30" conductor casing.

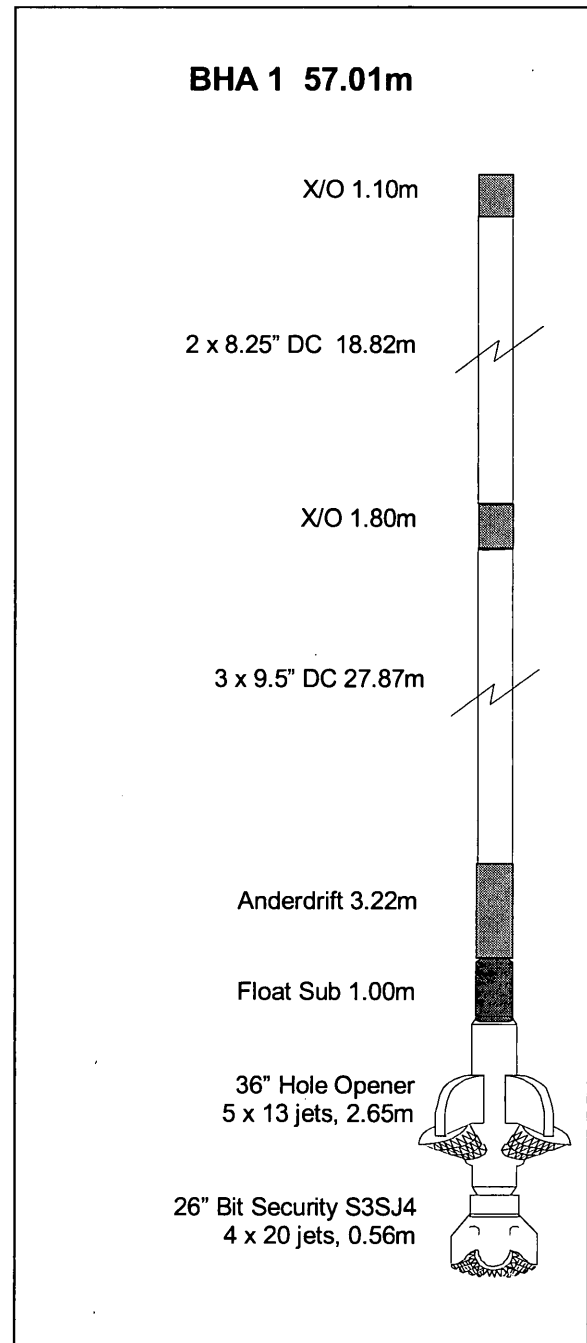

2.1

17.5" Phase : 27 - 28 July 2002**Bit Run 2 Summary**

Bit Number	NB 2
Bit Size	17.5"
Bit Type	Hycalog DS34HF+GN
S/N	244002
Jets	8 x 14
Depth In	122.5m
Depth Out	863m
Metres Drilled	740.5
Drilling Hours	14.8
TBR, krevs	108.35
Circulating Hours	21.0
Average ROP, m/hr	50.0
API Condition	1-1-NO-A-X-I-NO-TD

Drilling Parameters

WOB, klbs	1.6	-	17.6
RPM	75	-	148
Torque kft-lbs.	0.29	-	16.11
Pump Pressure, psi	568	-	3275
Flow In, gpm	776	-	1295

Mud System

Seawater & hi-viscosity	8.6 ppg
Gel Sweeps	

Lithology

Returns to seabed.

Drilling Summary

NB 2, a fixed cutter bit was made up to a packed drilling assembly and run in, tagging cement at 117m. After drilling out of the cement and the 20" casing shoe at 122.0m, new formation was drilled from 122.5m with 50bbls prehydrated gel (PHG) sweeps pumped every 15 metres drilled. Section TD was reached at 863m. A 100bbls hi-vis gel pill was swept around, followed by 300bbls of seawater. A 800bbl high-vis gel pill was then spotted. The hole was then wiped back to the 30" casing shoe at 122.0m. On the way back in no fill was recorded. Another 300bbls of seawater was pumped to clean the hole. The open hole was then displaced to weighted (12ppg) gel mud. The survey tool was dropped and the bit pulled out of the hole. There were no hole problems encountered on the trip out.

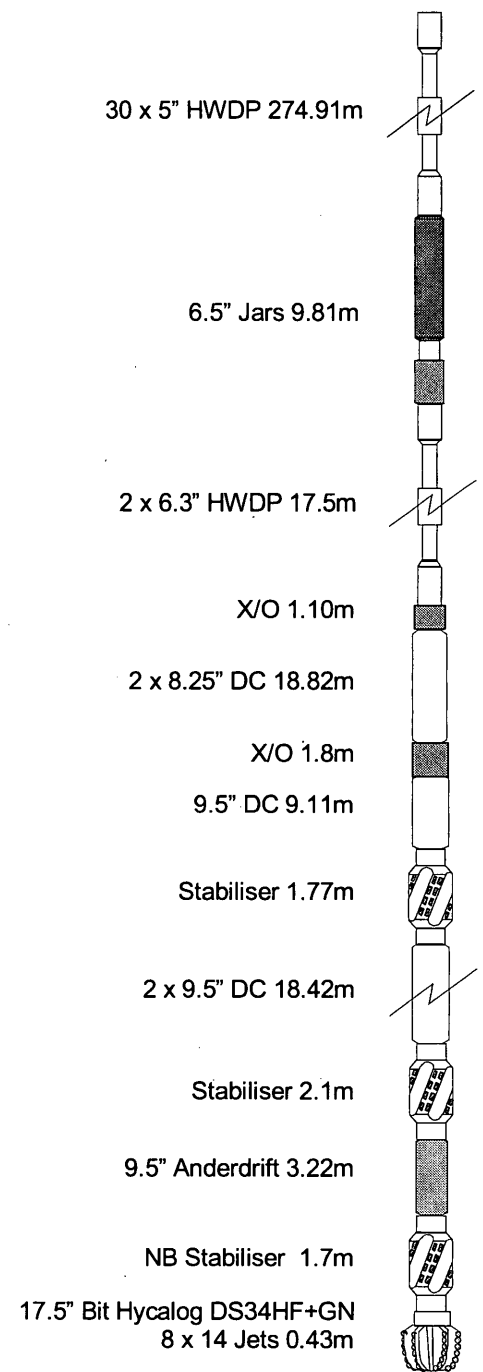
BHA 2 361.02m

12.25" Phase: 31 July – 3 August 2002

Bit Run 3 Summary

Bit Number	NB 3
Bit Size	12.25"
Bit Type	Reed - Hycalog
	DSX195DGNW
S/N	103092
Jets	5 x 14
Depth In	863m
Depth Out	1579m
Metres Drilled	716
Drilling Hours	28.1
TBR, krevs	263.9
Circulating Hours	33.3
Average ROP, m/hr	25.5
API Condition	5-8-LT-N-X-1-RO-PR

Drilling Parameters

WOB, klbs	0.2	-	30.5
RPM	61	-	205
Torque kft-lbs.	2.05	-	15.57
Pump Pressure, psi	1495	-	3696
Flow In, gpm	719	-	989

Mud System

KCI / PHPA / Glycol	8.9	-	9.8 ppg
---------------------	-----	---	---------

Lithology

Argillaceous Calcilutite, Argillaceous Calcisiltite, Calcilutite, Claystone, Siltstone, Sandstone, Coal, Carbonaceous Siltstone & Conglomeratic Sandstone.

Drilling Summary

After running BOPs and marine riser, NB 3 was made up to a locked conventional drilling assembly with MWD tool and run in, tagging cement at 820m. The hole was displaced to 8.9ppg KCI/PHPA/Glycol mud whilst drilling cement, shoe track, the casing shoe at 849.1m and three metres of new formation to 866m were drilled out. After circulating bottoms up, the bit was pulled back into the casing shoe and a Pressure Integrity Test (PIT) was performed. A surface pressure of 838psi exerted on the formation with 8.9ppg mud yielded an Equivalent Mud Weight (EMW) of 14.73ppg. Drilling resumed from 866m to 913m. Drilling was halted briefly to change out a backed out saver sub on the TDS. Drilling resumed from 913m and the mud weight was gradually increased to 9.5ppg, and then naturally increased to 9.8ppg by the end of the bit run. A maximum gas of 1.12% was seen at 1405m. The hole was drilled down to 1579m where it was decided to pull out of hole due to slow rates of penetration. Two tight spots were seen

BHA 3 364.94m

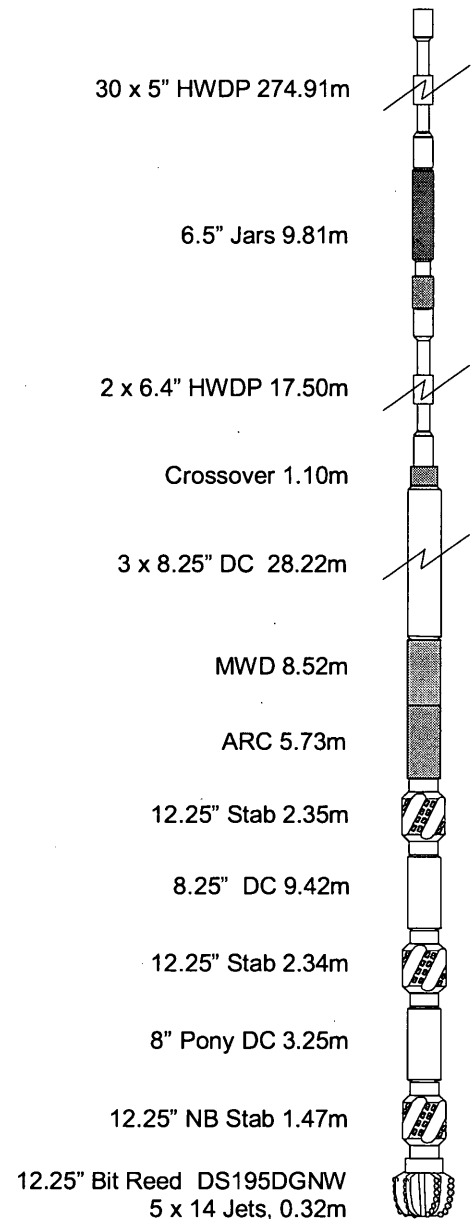

on the trip out both giving 20klbs of overpull at 1282m and 1098m. No other hole problems were noted on the trip out.

2.1

Bit Run 4 Summary

Bit Number	NB 4
Bit Size	12.25"
Bit Type	Reed EHP51HKPRDH
S/N	NL5038
Jets	3 x 18
Depth In	1579m
Depth Out	1905m
Metres Drilled	326
Drilling Hours	34.4
TBR, krevs	199.2
Circulating Hours	41.4
Average ROP, m/hr	9.5
API Condition	3-4-WT-A-E-2-NO-TD

Drilling Parameters

WOB, klbs	21.2	-	55.2
RPM	54	-	130
Torque kft-lbs.	2.49	-	7.7
Pump Pressure, psi	2753	-	3317
Flow In, gpm	806	-	876

Mud System

KCI / PHPA / Glycol 9.8 sg

Lithology

Sandstone, Coal, Siltstone, Claystone and Conglomeratic Sandstone.

Drilling Summary

NB4, a tricone insert bit, was made up on a rotary drilling assembly with in-string MWD & CDR tools and run in the hole. Fill was tagged at 1572m and the bit was washed and reamed down to bottom at 1579m. New 12.25" hole was drilled from 1579m to TD at 1905m where a 100bbl Hi-Vis pill was pumped and bottoms up circulated, before conducting a flow check (static) and pulling out of hole for a wiper trip. After 3 stands had been pulled tight hole was encountered with 60K overpull. The drillstring was made up to the top drive and circulation broken to condition the hole. The string was then pumped and rotated out of the hole to the 13.375" shoe and run back to bottom to complete the wiper trip. 6m of fill was encountered on the trip back to bottom. Bottoms up was circulated twice, large chunks of coal were seen at the shakers, this is suspected as the cause of the hole fill. After a flowcheck the bit was pulled out of hole to run wireline logs.

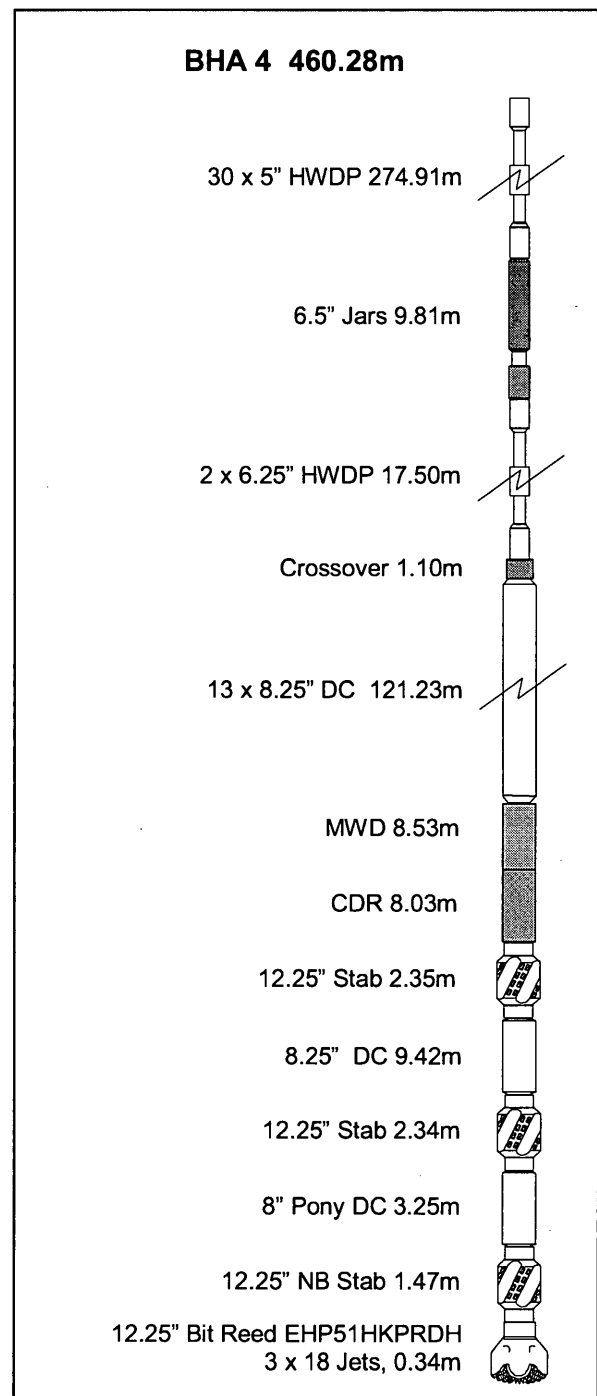

2.2 Casing and Cementing Summaries

30" Casing

Hole Size	36"
Depth	123.5m
Casing	
OD	30/20"
ID	27.5/18.6"
Weight	310 lb/ft X52

Shoe Depth 122.0m

Cement	Single Stage, Tail
Type	ABC Class G
sacks	1228 sx
Yield	2.56 cu-ft/sx
Slurry Density	15.9 ppg
Volume	125 bbls
Additives	1% CaCl ₂

Summary

The 30" conductor casing was run and the top joint made up to the PGB. The casing string was filled with seawater while lowering to sealevel and landed out with heavyweight drillpipe. At seabed, the ROV aided in stabbing the shoe joint into the hole after the rig was moved to proper alignment. The shoe was landed at 122m with the PGB set 1.0m above the mud line. The bullseye on the PGB indicated a deviation from level of 0.25 degree port-aft. After testing the cement lines to 2000 psi, the cement tail slurry of 256 bbls at 15.9 ppg weight was mixed and pumped. The floats were checked and because they had not held, pressure was maintained down the landing string with the cement unit for 3.5 hours to allow the cement to harden in place. The ROV monitored good returns throughout the cementing job. The full casing weight was slacked off and the running tool backed out. The running tool was then pulled out of hole.

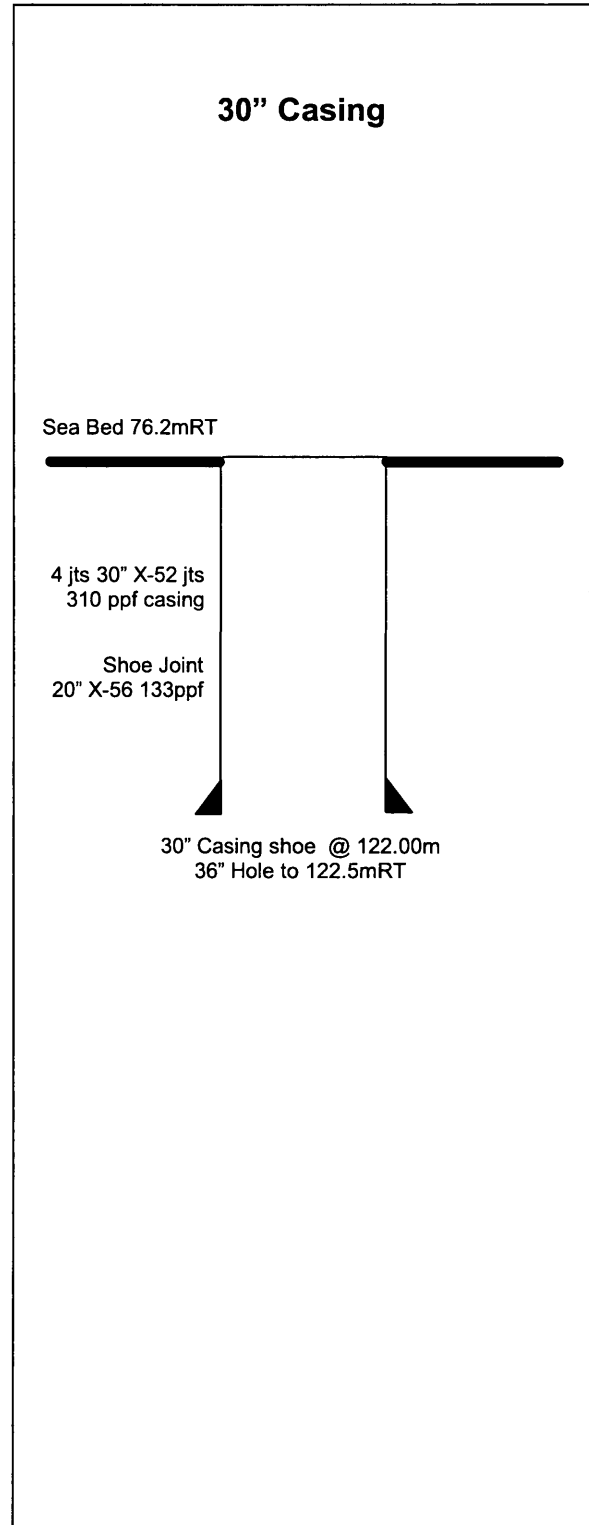

13.375" Casing

Hole Size	17.5"
Depth	863m
Casing OD	13.375"
ID	12.347"
Weight	68 lb/ft K-55 BTC
Shoe Depth	849.1m

Cement Type	Lead Slurry ABC class"G"
Sacks	1335 sx
Slurry Density	12.5 ppg
Yield	2.21 cu-ft/sx
Additives	Econolite/NF-5

Cement Type	Tail Slurry class"G"
Sacks	726sx
Slurry Density	15.8 ppg
Yield	1.16 cu-ft/sx
Mix Water	5.15 gal/sx

Summary

Sixty-four joints of 13.375" casing including the shoe and housing joint were run and landed, setting the shoe at 849.1m. The casing was circulated with 500 bbls seawater prior to cementing. The cement lines were pressure-tested to 2500psi for 3 minutes. The lead slurry of 523 bbls at 12.5 ppg, followed by 150 bbls of 15.8 ppg tail slurry. The dart was released and the cement was displaced with 5bbls of drillwater to shear the plug followed by 5bbls of drillwater. The cement was displaced with the rig pumps, pumping 363 bbls of seawater. The plug did not bump. Pressure was held for two minutes after pumping, then bled off after the floats were checked to be holding.

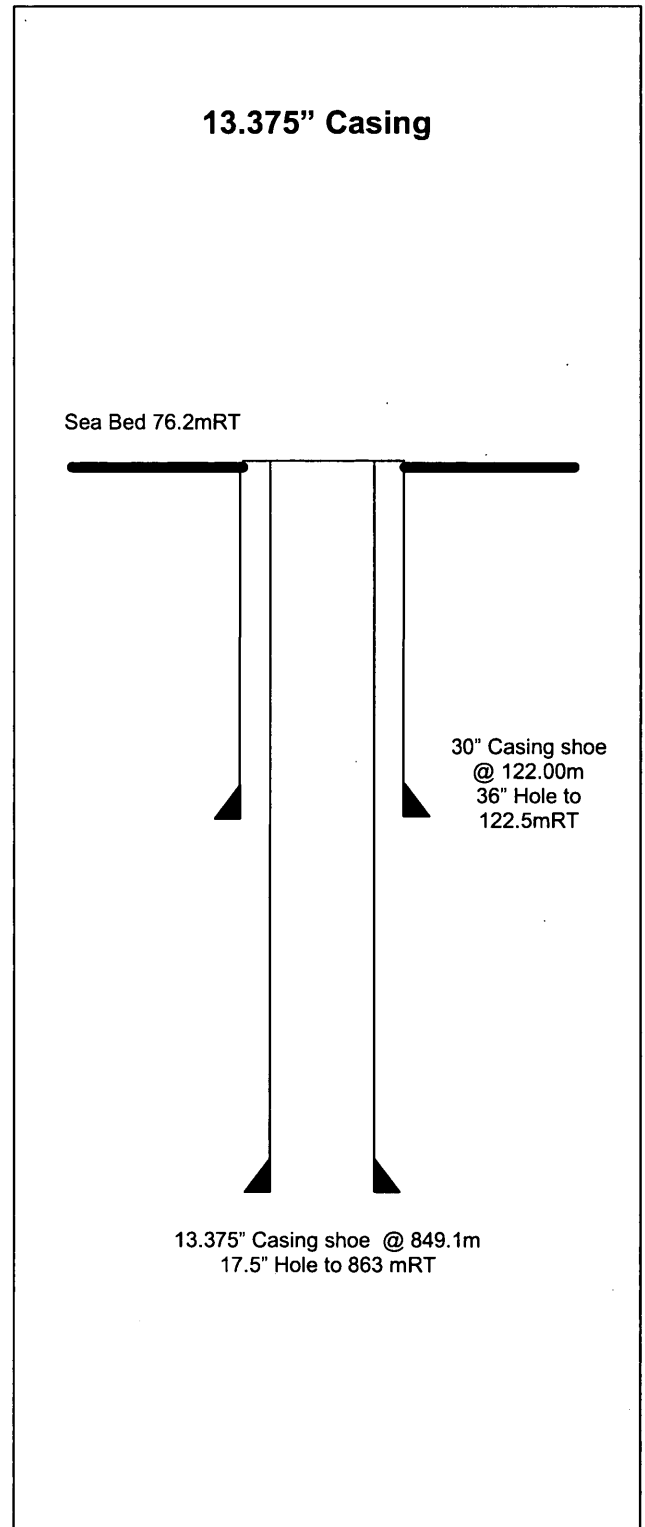

Section 3

Geology and Shows

GEOLOGY AND SHOWS

Formation Evaluation for Beardie - 1 commenced from below the 13.375" casing shoe at 849.1m MDRT to the well's Total Depth of 1905m MDRT. Sampling rates were dependent on rate of penetration. Washed and lightly washed (Palynology) cuttings samples were collected at the following intervals:

From (m)	To (m)	Sampling Interval (m)
863	890	27
890	920	30
920	1430	5
1430	1500	10
1500	1905	5

During the course of the well, all gas equipment was checked and calibrated before drilling.

The lithological units observed during the drilling of Beardie – 1 are described below. For more detailed descriptions, see Appendix-1, Formation Evaluation Log.

36" HOLE SECTION

Seabed to 123.5m: Returns to Seabed

17.5" HOLE SECTION

123.5m to 863m: Returns to Seabed

12.25" HOLE SECTION

863m to 1065m: ARGILLACEOUS CALCILUTITE

ARGILLACEOUS CALCILUTITE: White to very light grey, light grey, medium light grey to medium dark grey, light olive grey to olive grey, brown grey. Soft to moderately hard, occasionally friable, subblocky to blocky, occasionally amorphous with abundant argillaceous matrix, trace glauconite, trace pyrite, trace carbonaceous material, trace recrystallised calcite, trace crystalline calcite, trace echinoid spines and trace Foraminifera. Grading to CALCAREOUS CLAYSTONE in places.

There were no oil shows in this interval.

1065m to 1195m: ARGILLACEOUS CALCILUTITE, ARGILLACEOUS CALCISILTITE, SANDSTONE with minor CALCILUTITE and CLAYSTONE

ARGILLACEOUS CALCILUTITE: White, very light to light grey, medium to medium dark grey, olive grey to brownish grey. Soft to firm, amorphous to subblocky with abundant argillaceous matrix, rare glauconite pellets, trace carbonaceous material, trace recrystallised calcite, trace glauconite, trace disseminated and nodular pyrite, trace Foraminifera. Grading to CALCAREOUS CLAYSTONE in places.

CALCILUTITE: White to very light grey. Soft to firm, amorphous to subblocky with trace glauconite.

ARGILLACEOUS CALCISILTITE: White to light grey, medium grey to medium dark grey. Soft to moderately hard, amorphous to subblocky with common glauconite, trace carbonaceous material and trace crystalline calcite.

SANDSTONE: White to light grey. Translucent, occasionally clear quartz grains, loose, occasionally moderately hard to hard aggregates. Fine to coarse, predominantly medium to coarse, trace very coarse grains, subangular to rounded, predominantly subrounded, subelongate to spherical, poorly to moderately well sorted. Trace pyrite cement, trace calcareous cement and trace carbonaceous material. Fair to good inferred porosity, poor visual porosity.

CLAYSTONE: White, very light grey, light olive grey, pale yellowish brown. Soft, amorphous to subblocky, common siderite staining, minor green and dark green moderately coarse grained glauconite, rare fine quartz grains and trace disseminated pyrite.

There were no oil shows in this interval.

1195m to 1405m: Interbedded SANDSTONE, COAL and minor SILTSTONE

SANDSTONE: White to light grey, medium light grey. Clear to translucent quartz grains, predominantly loose, common fine grained hard aggregates, fine to very coarse grained, predominantly moderately coarse, occasionally granular, rare pebbles, subrounded to rounded, occasionally subangular, subelongate to spherical, trace fractured grains, poor to moderately well sorted with trace to abundant slightly calcareous argillaceous matrix. Rare disseminated and nodular pyrite, rare to trace pyrite cement, trace to common mica, trace glauconite pellets, trace carbonaceous material, trace coal and trace Foraminifera. Poor to fair visual porosity, poor to good inferred porosity.

COAL: Medium brown, dusky brown, brownish black, olive black, greyish black to black. Subvitreous to vitreous, brittle to moderately hard, occasionally hard, blocky, angular to sub-conchoidal, conchoidal in places with trace disseminated pyrite. Grades to CARBONACEOUS SILTSTONE in places.

SILTSTONE: Medium light grey to light grey, light olive grey. Soft, amorphous to subblocky with common very fine quartz grains, trace pyrite and trace glauconite.

There were no oil shows in this interval.

1405m to 1555m SANDSTONE with interbedded COAL, SILTSTONE and minor CARBONACEOUS SILTSTONE

SANDSTONE: Clear to translucent and occasionally grey and orange stained quartz grains, fine to coarse grained, predominantly medium to coarse, rare pebbles, loose, angular to subrounded, occasionally rounded, subelongate to subspherical, rare to trace fractured grains, moderately well sorted containing trace white argillaceous matrix, rare to trace pyrite cement and trace glauconite. Poor to good inferred porosity.

COAL: Greyish black to black, brownish black to olive black. Firm to moderately hard, vitreous, blocky, sub-conchoidal to conchoidal fracture. Grading to a CARBONACEOUS SILTSTONE in places.

SILTSTONE: Moderate yellowish brown to light pale brown, greyish orange pink, pale yellowish orange, greyish brown, mottled texture in places. Soft to firm, occasionally moderately hard, subblocky to subfissile with carbonaceous microlaminations, common carbonaceous material, trace nodular and disseminated pyrite and trace mica. Grading to a CARBONACEOUS SILTSTONE.

CARBONACEOUS SILTSTONE: Brownish grey to dark yellowish brown, moderate yellowish brown. Soft, subfissile, subblocky to blocky, with carbonaceous microlaminations and trace disseminated pyrite. Grading to SILTSTONE in places.

There were no oil shows in this interval.

3.1

1555m to 1625m: SANDSTONE and CONGLOMERATIC SANDSTONE with Interbedded COAL and SILTSTONE

SANDSTONE: Clear to translucent quartz grains, loose, common very hard aggregates, fine to very coarse grained, subrounded to subangular, common to abundant fractured grains, subspherical, poorly sorted with common hard dolomite cement, trace pyrite, trace glauconite. Poor visual porosity. Dolomite fluorescence: light yellowish green.

CONGLOMERATIC SANDSTONE: Clear to translucent quartz grains, loose, fine to very coarse with occasional granules, predominantly medium to coarse, subangular occasionally subrounded, common fractured grains, subelongate to subspherical, poorly sorted. Contains common hard, dolomite cement, which is medium grey to dark grey, greyish orange in colour, trace pyrite cement, trace nodular pyrite and trace glauconite pellets. Poor visual porosity. Dolomite fluorescence: Bright greenish yellow.

COAL: Greyish black to black, brownish black to olive black. Firm to moderately hard, vitreous, blocky, sub-conchoidal to conchoidal fracture. Grading to a CARBONACEOUS SILTSTONE in places.

SILTSTONE: Moderate yellowish brown to light pale brown, greyish orange pink, pale yellowish orange, greyish brown, mottled texture in places. Soft to firm, occasionally moderately hard, subblocky to sub-fissile with carbonaceous microlaminations, common carbonaceous material, trace nodular and disseminated pyrite and trace mica. Grading to a CARBONACEOUS SILTSTONE.

There were no oil shows in this interval.

1625m to 1780m: Interbedded SANDSTONE, SILTSTONE and COAL

SANDSTONE: Clear to translucent quartz grains, loose, trace hard aggregates, fine to very coarse, angular to subrounded, subelongate to subspherical, poor to moderate sorting with rare pyrite cement, trace argillaceous matrix, trace mica flakes, trace pyrite nodules and trace glauconite. Poor to fair inferred porosity, poor visible porosity.

COAL: Dusky brown to black, greyish black. Subvitreous to vitreous, firm to moderately hard, blocky, angular to sub-conchoidal with trace disseminated pyrite.

SILTSTONE: Dusky brown to dusky yellowish brown, light brownish grey, medium light grey to light grey, light olive grey, yellowish grey, occasional moderate yellowish brown, occasional medium grey. Soft to moderately hard, amorphous to subblocky, occasionally subfissile, with trace to minor carbonaceous laminations, trace to minor carbonaceous specks and trace disseminated pyrite. Grading to CARBONACEOUS SILTSTONE and CLAYSTONE in places.

CLAYSTONE: Pale yellowish brown to dusky yellowish brown, occasional light brown. Soft, amorphous to subblocky. Grading to a SILTSTONE in places.

There were no oil shows in this interval.

1780m to 1905m: SANDSTONE and CLAYSTONE with minor interbedded SILTSTONE and COAL

SANDSTONE: Clear to translucent quartz grains, rare medium light grey to medium grey opaque grains. Loose, with trace hard aggregates, fine to coarse grained, predominantly medium to coarse, angular to subrounded, subelongate to subspherical, minor to abundant fractured grains, moderately sorted containing trace dolomite cement, trace to rare pyrite cement, trace pyrite nodules, trace glauconite and trace mica flakes. Fair to good inferred porosity, poor visible porosity.

CLAYSTONE: Pale yellowish brown, light olive grey, very light grey to medium grey, occasionally brownish grey, occasionally greyish brown to dusky brown. Soft to firm, amorphous to subblocky with trace pyrite, and trace carbonaceous specks. Grades to SILTSTONE in places.

SILTSTONE: Light brownish grey, medium light grey to light grey, light olive grey, yellowish grey, light brown to moderate brown. Soft to firm, subfissile to fissile, subblocky, with trace disseminated pyrite, trace carbonaceous specks and trace of carbonaceous microlaminations.

COAL: Black to brownish black, olive black, dusky yellowish brown. Subvitreous to vitreous, firm to moderately hard, subblocky to blocky, sub-conchoidal fracture with trace to common disseminated pyrite.

There were no oil shows in this interval.

3.1

Drilling Rate Summary for All Lithology Intervals on Beardie-1			
Depth Interval (m)	RATE OF PENETRATION (m/hr)		
	Minimum	Maximum	Average
863 - 1065	8.6	64.3	27.9
1065 - 1195	11.5	139.5	29.9
1195 - 1405	1.7	160.0	53.7
1405 - 1555	10.3	168.2	56.1
1555 - 1625	0.8	56.3	18.3
1625 - 1780	4.7	63.3	25.2
1780 - 1905	2.1	55.9	15.2

Summary of Gas Readings Recorded for All Lithology Intervals on Beardie-1													
Interval (m)		Total Gas (%)				Chromatograph Analysis (percent %)							
From	To	Range		Max Gas	Av. Total		C1	C2	C3	iC4	NC4	IC5	nC5
		From	To	at (m)	Gas								
0	863	Returns to Seabed				Min	-	-	-	-	-	-	-
					Max								
863	1065	0.0	0.03	997-998,1006 1012-1018	0.02	Min	0.0027	-	-	-	-	-	-
						Max	0.280						
1065	1195	0.01	0.26	1192	0.05	Min	0.0054	-	-	-	-	-	-
						Max	0.2031	0.0182	0.007				
1195	1405	0.04	0.92	1236	0.24	Min	0.0190	-	-	-	-	-	-
						Max	0.6559	0.0610	0.0250	0.009	0.0057	0.0095	0.003
1405	1555	0.10	1.14	1413	0.22	Min	0.0180	-	0.0019	-	-	-	-
						Max	0.1534	0.0390	0.0265	0.0111	0.0253	0.0250	0.0223
1555	1625	0.03	0.22	1625	0.08	Min	0.0095	-	-	-	-	-	-
						Max	0.0907	0.0235	0.0144	-	0.0014	0.0010	0.0015
1625	1780	0.04	4.57	1676	0.35	Min	0.0180	0.0060	0.0049	-	-	-	-
						Max	3.4004	0.4665	0.1110	0.0181	0.0295	0.0081	0.0089
1780	1905	0.01	0.23	1792-1793	0.06	Min	0.0125	-	-	-	-	-	-
						Max	0.2551	0.0279	0.0101	0.0006	0.0022	-	-



INTEQ

3.2 SAMPLES DISTRIBUTION LIST
 ESSO AUSTRALIA PTY LTD
 Beardie -1

CONTAINER: SC 283

SAMPLE TYPE	No. of Sets	COMPOSITION			PACKING DETAILS
		Sample	Depth Interval (m)		
		Box No.	From	To	
Set A (200g) : Lightly Washed & Air Dried Palynology	1	1	863	1150	Packed into 4 large boxes.
		2	1150	1400	
		3	1400	1700	
		4	1700	1905	
Sets B, C, D, E (100g) : Washed & Dried	4	1	863	1000	Small boxes 1-8 are packed in large Box 1
		2	1000	1110	
		3	1110	1200	
		4	1200	1300	
		5	1300	1400	
		6	1400	1540	
		7	1540	1630	
		8	1630	1725	
		9	1725	1825	Small boxes 9-10 are taped Together making large Box 2.
		10	1825	1905	
Set F: Charts & Worksheets	1	-	-	-	1 Large Box.
Set G: Mud Samples (890m, 1200m, 1579m, 1675m, 1905m)	1	1	863	1905	Packed in 1 large Box.
Sidewall Core Samples	1	1			1 large box handcarried to Melbourne by WSG



INTEQ

3.2 SAMPLES DISTRIBUTION LIST
 ESSO AUSTRALIA PTY LTD
 Beardie -1



ALL BOXES TO BE SENT TO KESTREL WAREHOUSE FOR ONWARD DISTRIBUTION:

DISTRIBUTION	Destination & Address	Attention of:
Lightly Washed & Dried (Palynology) Set A: ESSO	ESSO c/o Kestral Information Management 596-600 Somerville Rd SUNSHINE, VIC 3020	Diana Giodano Core/Archive Supervisor
Washed & Dried Set B: ESSO	ESSO c/o Kestral Information Management 596-600 Somerville Rd SUNSHINE, VIC 3020	Diana Giodano Core/Archive Supervisor
Washed & Dried Set C: BHPP	BHPP c/o Kestral Information Management 596-600 Somerville Rd SUNSHINE, VIC 3020	Diana Giodano Core/Archive Supervisor
Washed & Dried Set D: VIC DNRE	DNRE Core Sample Library South Rd. (off Sneydes Rd) WERRIBEE, Victoria, 3030	Note: To be forwarded to VIC DNRE after 2 days notification
Washed & Dried Set E: AGSO	AGSO Data Repository Cnr Jerrabomberra Ave and Hindmarsh Drive SYMONSTON, ACT, 2609	Eddie Resiak
Charts & Worksheets	ESSO c/o Kestral Information Management 596-600 Somerville Rd Sunshine, VIC 3020	Ops Geologist Andrew Hodgson, ESSO, Melbourne

913713 079

Section 4

Pressure Evaluation

4.1 PORE PRESSURE EVALUATION

An average sea water density of 8.6 ppg was assumed as the normal saline pressure gradient for all calculations for Beardie-1. Using real-time data, such as the hydrocarbon gas trend, lithology, flowline temperature, character of drilled cuttings, constant drilling fluid parameters, corrected drilling exponent (DxC) data, as well as wireline logging data when available, pore pressure estimates were made during the drilling of Beardie-1. For more details, please refer to Appendix 3, "Pressure Summary Plot".

36" Hole Section

The 36" hole was drilled from seabed at 76.2mMDRT to 122.5m with NB#1 Security S3SJ4, 26" and a 36" hole opener. The section was short, with returns dumped to the seabed. With an average penetration rate of about 46m/hr and low weight-on-bit 3-8 klbs, the plotted DxC data curve showed no decent trend for a possible pressure evaluation. The wide DxC scatter suggested strong jetting of the formation. The variations in the penetration rates, 6.7 – 70.6m/hr and the DxC, 0.52 - 0.99 units over this shallow interval were also due to the varying drillability of the lithologies consisting of very soft, possibly unconsolidated sediments and cemented calcarenite. The pore pressure was estimated to be normal at 8.6ppg EMW from the seabed down to 122.5mMDRT.

17½" Hole Section

This section was drilled from 122.5m to 863m with a PDC bit, NB#2 Hycalog, DS34HF+GN 17.5" with 8x14 jets. As in the 36" section, pore pressure estimates were based on the DxC curve, penetration rate and the behaviour of available drilling parameters (torque and pump pressure), since drilling was done riserless and returns were directed to the seabed. The DxC ranged between 0.27 – 1.24 over the section, the use of a PDC bit hinders the value of using DxC as a method of pressure evaluation. No signs of abnormal pressure were noted over the section. The hole was kept clean by circulating guar gum sweeps every joint drilled and prehydrated gel spotted at each connection. There was no abnormal torque, drag or hole problems throughout the section. The pore pressure was estimated to be normal at 8.6 ppg EMW from 122.5 down to 863m.

12 ¼" Hole Section

The 12¼" hole section was drilled initially with NB#3 Reed Hycalog DSX195DGNUW PDC bit, with 5x15 jets from 863m to 1579m. Prior to drilling, the hole was displaced and conditioned to a KCI/PHPA/Glycol mud system weighing 8.9 ppg. Pore pressure estimation, due to the use of the PDC bit, relied on the relationship of mud weight, gas and cavings, and the temperature log and drilling parameters rather than corrected drilling exponent data.

From 863m to 1190m the bit drilled argillaceous calcilutites and occasional calcisiltites and calcareous claystones at 8 - 64m/hr, averaging 23.5 m/hr. Normal pressure at 8.6 ppg EMW in this section was indicated by the low background gas, (0 – 0.14%), no connection gas, rare to trace amounts of splintery cavings and the temperature gradient 0.09 °C/m (22.8 – 51.7°C). There was no drag seen at connections while drilling and the torque was low at 6.7 kft-lb average. With 8.9-9.5 ppg mud in the hole, a slightly overbalanced condition was in place.

From 1190m to 1579m the lithologies changed to the target sandstones with occasional coal beds. Penetration in this section ranged from 0.8 - 168 m/hr, averaging 27.4 m/hr. The mudweight ranged between 9.5 ppg and 9.8ppg. The ditch gas was maintained at 0.04 – 1.14% units background with no distinct peaks and no connection gases recorded. The flowline temperature slightly decreased its gradient to 0.03 °C/m with a range of 49.3 – 63.1°C. The pore pressure at this section remained normal at 8.6 ppg EMW. No pressure cavings were seen in the section, however large blocky coal cavings were seen after drilling through coal beds. This is thought to be related to the stability of the coal beds and not as a result of a pore pressure increase.

New bit #4, a Reed EHP51HKPRDH tricone bit with 3 x 18 jets was used to drill the hole from 1579m to total depth of 1905m.

From 1579m to 1880m the lithologies were mainly sandstones, siltstones and minor shales and coals. From 1880m to TD at 1905m claystone was the dominant lithology. The rate of penetration ranged from 2.1 – 63.3 m/hr and averaged 9.5m/hr. The background gas stayed in the range 0.02 – 0.2% with peaks of up to 4.67%, liberated from the coalbeds and occasionally from the sandstones. Connection gas was absent. The flowline temperature ranging 52.6°C – 61.5°C had a gradient of 0.03°C/m, the same as that of the overlying sediments. The cuttings and the cavings increased in volume and size. The cavings were mostly of coal dominated by the blocky stress-relief type, with very rare splintery and concave-shaped cavings. The pore pressure at this section was estimated to have remained normal at 8.6 ppg EMW. No notable drag and fill at the bottom was observed while drilling and after connections. However, seven metres of fill was recorded on the trip in with bit #4 and six metres of fill recorded after the wiper trip to the shoe at TD. On both occasions the hole fill is thought to have been caused by coal, large coal cavings were seen at the shakers upon bottoms up. This was thought to be unrelated to any pore pressure increase but rather to the general instability of the coal formations. The hole was tight on the wiper trip and the bit was backreamed to 1579m, no other hole problems were seen on rest the wiper trip or on the trip out to run e-logs. The pore pressure gradient at TD was thought to have remained normal at 8.6 ppg EMW.

4.2 FRACTURE PRESSURE EVALUATION

Fracture pressure estimation for Beardie-1 was made using the Baker Hughes INTEQ zero tensile strength method. For a full explanation of this method, refer to INTEQ Manual MS-156 "The Theory and Evaluation of Formation Pressures".

With no returns to surface it was not possible to estimate the fracture pressure through the 36 and 17.5" hole sections. A Pressure Integrity Tests (PIT) was performed at the 13.375" casing shoe, with the result shown below:

Casing Depth	Casing Size		Hole Size		Test Mud Density	FIT EMW	Test type
	in	mm	in	mm	(ppg)	(ppg)	
849.1	13.375	340	12.25	311	8.9	14.73	PIT

The 13.375" casing was run and set at 849.1m. The 12.25" assembly was made-up and RIH. After drilling cement, casing shoe and new hole to 866m, the hole was displaced to a KCL/PHPA/Glycol water-based mud system weighted at 8.9 ppg. A Pressure Integrity Test was then performed recording a 14.73ppg EMW formation strength. Drilling resumed with occasional surface losses, but no downhole losses. The system was weighted up to 9.5ppg before the Lakes Entrance formation was penetrated. At 1150m, Baracarb limestone Loss Circulation Material was then gradually added to the drilling fluid to minimise seepage loss to the Latrobe sands. Further additions of KCL and Baracarb then increased the mud weight to 9.8 ppg without significant fluid loss to the formation. The maximum effective circulating density exerted by the rig pumps was calculated at 10.0ppg. This value was way below the 14.73 ppg EMW strength of the casing shoe.

Tables

Table 1: Bit Run Summary

Tables

OPERATOR		WELL NAME		LOCATION				CONTRACTOR		VIC/I/L2				REASONS PULLED													
ESSEO AUSTRALIA PTY LTD		BEARDIE-1		DIAMOND OFFSHORE GENERAL COMPANY				MODU OCEAN BOUNTY																			
				BIT/DULL CHARACTERISTICS																							
BIT RUN No.	MAKE	TYPE	TFA sq.in.	JETS	SERIAL No.	DEPTH IN m	METRES ON BIT	HRS ON BOTTOM	AV ROP m/hr	IADC HRS	WOB kibs	RPM S/M	TBR krevs	SPP psi	GPM	TQ	GRADE	I	O	D	L	B	G	O	R	MW ppq	REMARKS
		PUMP 1 - OILWELL A1700 PT 6" LINER (36, 17.5 & 12.25) PUMP 2 - OILWELL A1700 PT 6" LINER (36, 17.5 & 12.25) PUMP 3 - OILWELL A1700 PT 6" LINER (36, 17.5 & 12.25)																									
1	NB1	Security	1.875	4x20, (5x13)	SER 668369	76.2	47.3	1.0	47.3	2.0	3.3-8.7	74 / -	6.2	160-952	508-1083	0.9-5.6	2	2	NO	A	E	I	NO	TD	8.6	With 36" Hole Opener	
		17.5" HOLE SECTION 123.5 - 863mMDRT																									
2	NB2	Hycalog	1.203	8 x 14	244002	122.5	739.5	14.8	50.0	21.0	1.6-17.6	117 / -	108.4	568-3275	776-1295	0.29-16.11	1	1	NO	A	X	I	NO	TD	8.6		
		12.25" HOLE SECTION 863 - 1579mMDRT																									
3	NB3	Reed/Hycalog	0.752	5 x 14	103092	863	716	28.1	25.5	36.75	0.2-30.5	167 / -	263.9	1495-3696	719-989	2.05-15.57	5	8	LT	N	X	1	RO	PR	8.9-9.8	MWD	
4	NB4	Reed	0.746	3 x 18	NL5038	1579	326	34.4	9.5	39.5	21.2-55.2	102 / -	199.2	2753-3317	806-876	2.49-7.70	3	4	WT	A	E	2	NO	TD	9.8	MWD	

Table 2: Bit Hydraulics Summary

OPERATOR		WELL NAME		LOCATION		CONTRACTOR		RIG														
ESSE AUSTRALIA PTY LTD		BEARDIE-1		VIC/L2		Diamond Offshore General Co.		MODU OCEAN BOUNTY														
Drillstring Abbreviations																						
Bit No.	Depth In (m)	N Hole Size in	M MWD	Normal Calc'd Hole Size in	T JETS x 1/32"	C Core	Turbine Corc	P Mud Density ppg	Positive Displacement Motor													
										Mud Type	PV / YP	Flow Rate gpm	ECD ppg	DP Riser m/min	DP OH m/min	DC OH m/min	DC critical m/min	Jet Vel m/sec	HHP hp	HSI hp/sg in	Impact Force lbf	Bit Pressure Loss psi
36"726" HOLE SECTION																						
76.2 - 123.5mMDRT																						
NB1	76.2	36/26	36	4x20 (5x13)	N	N	8.6	SW / Gel sweeps	1 / 1	1083	8.6	8.6	6.7	25.2	56.5	166.7	0.3	893.9	264	50.5	523	952
17.5" HOLE SECTION																						
123.5 - 863mMDRT																						
NB2	122.5	17.5	17.5	8 x 14	N	N	8.6	SW / Gel sweeps	1 / 1	1295	8.6	8.6	44.8	25.48	105.3	693.1	2.9	1993.2	918	33.3	2755	3275
12.25" HOLE SECTION																						
863 - 1905mMDRT																						
NB3	863	12.25	12.25	5 x 14	MWD	MWD	9.8	KC/PIPA/Glycol	18 / 26	989	10.0	10.0	90.1	140.95	128.7	900.4	7.8	2119.3	1562	42.3	3695	3696
NB4	1579	12.25	12.25	3 x 18	MWD	MWD	9.8	KC/PIPA/Glycol	20 / 32	833	10.0	10.0	75.9	160.5	109.3	547.0	4.7	1516.0	1127	33.8	3335	3317



Table 2: BIT HYDRAULICS SUMMARY

Table 3: Survey Data Summary

Esso Australia Pty Ltd
Beardie-1

July - August 2002

Latitude:	38° 15' 16.214" S	Field Strength, HCNT:	1202.85
Longitude:	147° 48' 24.643" E	Grid Convergence:	-0.50°
Section Azimuth:	0.00	Total Azimuth Corr:	13.45°
Dip:	-68.85°	North Reference:	Grid North
Declination:	12.95°	Computation Method:	Minimum Curvature

Directional Survey Listing

MEASURED DEPTH (m)	INCLINATION ANGLE (deg)	AZIMUTH ANGLE (deg)	VERTICAL DEPTH (m)	LATITUDE +N/S- (m)	DEPARTURE +E/W- (m)	VERTICAL SECTION (m)	DOGLEG (deg/10 m)	Survey Type
0.00	0.00	0.00	0.00	0.00	0.00	0	0.00	TIP
75.80	0.00	0.00	75.80	0.00	0.00	0	0.00	GYR
103.70	0.15	148.92	103.70	-0.03	0.02	-0.03	0.05	GYR
130.50	0.12	223.02	130.50	-0.08	0.02	-0.08	0.06	GYR
157.50	0.05	236.77	157.50	-0.11	-0.01	-0.11	0.03	GYR
184.20	0.05	297.06	184.20	-0.11	-0.03	-0.11	0.02	GYR
212.20	0.07	153.34	212.20	-0.12	-0.03	-0.12	0.04	GYR
240.40	0.04	159.19	240.40	-0.14	-0.02	-0.14	0.01	GYR
268.60	0.09	144.59	268.60	-0.17	-0.01	-0.17	0.02	GYR
296.30	0.07	298.19	296.30	-0.18	-0.01	-0.18	0.06	GYR
324.10	0.10	212.83	324.10	-0.19	-0.04	-0.19	0.04	GYR
351.70	0.24	245.32	351.70	-0.24	-0.10	-0.24	0.06	GYR
380.50	0.37	241.18	380.50	-0.31	-0.24	-0.31	0.05	GYR
409.60	0.36	254.31	409.60	-0.38	-0.41	-0.38	0.03	GYR
438.60	0.38	243.71	438.60	-0.45	-0.58	-0.45	0.02	GYR
467.20	0.30	227.88	467.20	-0.54	-0.72	-0.54	0.04	GYR
496.30	0.40	206.80	496.30	-0.68	-0.83	-0.68	0.06	GYR
525.20	0.41	205.20	525.20	-0.86	-0.92	-0.86	0.01	GYR
553.90	0.44	205.99	553.90	-1.05	-1.01	-1.05	0.01	GYR
583.20	0.45	201.04	583.19	-1.26	-1.10	-1.26	0.01	GYR
612.10	0.42	202.70	612.09	-1.47	-1.18	-1.47	0.01	GYR
641.10	0.48	206.49	641.09	-1.67	-1.28	-1.67	0.02	GYR
669.80	0.46	203.26	669.79	-1.89	-1.37	-1.89	0.01	GYR
698.80	0.48	202.05	698.79	-2.11	-1.47	-2.11	0.01	GYR
727.90	0.50	195.89	727.89	-2.34	-1.55	-2.34	0.02	GYR
757.00	0.52	180.34	756.99	-2.60	-1.58	-2.6	0.05	GYR
786.20	0.52	176.91	786.19	-2.86	-1.58	-2.86	0.01	GYR
814.70	0.58	177.65	814.69	-3.13	-1.56	-3.13	0.02	GYR
843.60	0.55	168.87	843.58	-3.42	-1.53	-3.42	0.03	GYR
852.70	0.56	173.86	852.68	-3.50	-1.52	-3.5	0.05	GYR
907.95	0.55	184.35	907.93	-4.04	-1.51	-4.04	0.02	MWD
1025.73	0.60	210.10	1025.71	-5.13	-1.86	-5.13	0.02	MWD
1083.00	0.46	228.69	1082.97	-5.54	-2.18	-5.54	0.04	MWD
1169.99	0.47	231.26	1169.96	-6	-2.72	-6	0	MWD
1257.42	0.51	245.44	1257.39	-6.38	-3.36	-6.38	0.01	MWD
1344.31	0.67	230.55	1344.27	-6.87	-4.1	-6.87	0.03	MWD
1431.33	0.79	216.92	1431.29	-7.67	-4.85	-7.67	0.02	MWD
1517.17	1.19	222.49	1517.11	-8.8	-5.81	-8.8	0.05	MWD
1551.21	1.09	226.63	1551.15	-9.28	-6.29	-9.28	0.04	MWD
1639.11	0.83	214.91	1639.03	-10.38	-7.26	-10.38	0.04	MWD

Table 3: Survey Data Summary

MEASURED DEPTH (m)	INCLINATION ANGLE (deg)	AZIMUTH ANGLE (deg)	VERTICAL DEPTH (m)	LATITUDE +N/S- (m)	DEPARTURE +E/W- (m)	VERTICAL SECTION (m)	DOGLEG (deg/10 m)	Survey Type
1725.47	0.90	209.82	1725.38	-11.48	-7.95	-11.48	0.01	MWD
1754.65	0.83	200.48	1754.56	-11.88	-8.14	-11.88	0.05	MWD
1834.52	0.89	216.64	1834.42	-12.92	-8.71	-12.92	0.03	MWD
1869.06	0.98	215.87	1868.96	-13.37	-9.05	-13.37	0.03	MWD



ESSO AUSTRALIA PTY LTD
BEARDIE-1



Time vs. Depth Curve

INTEQ

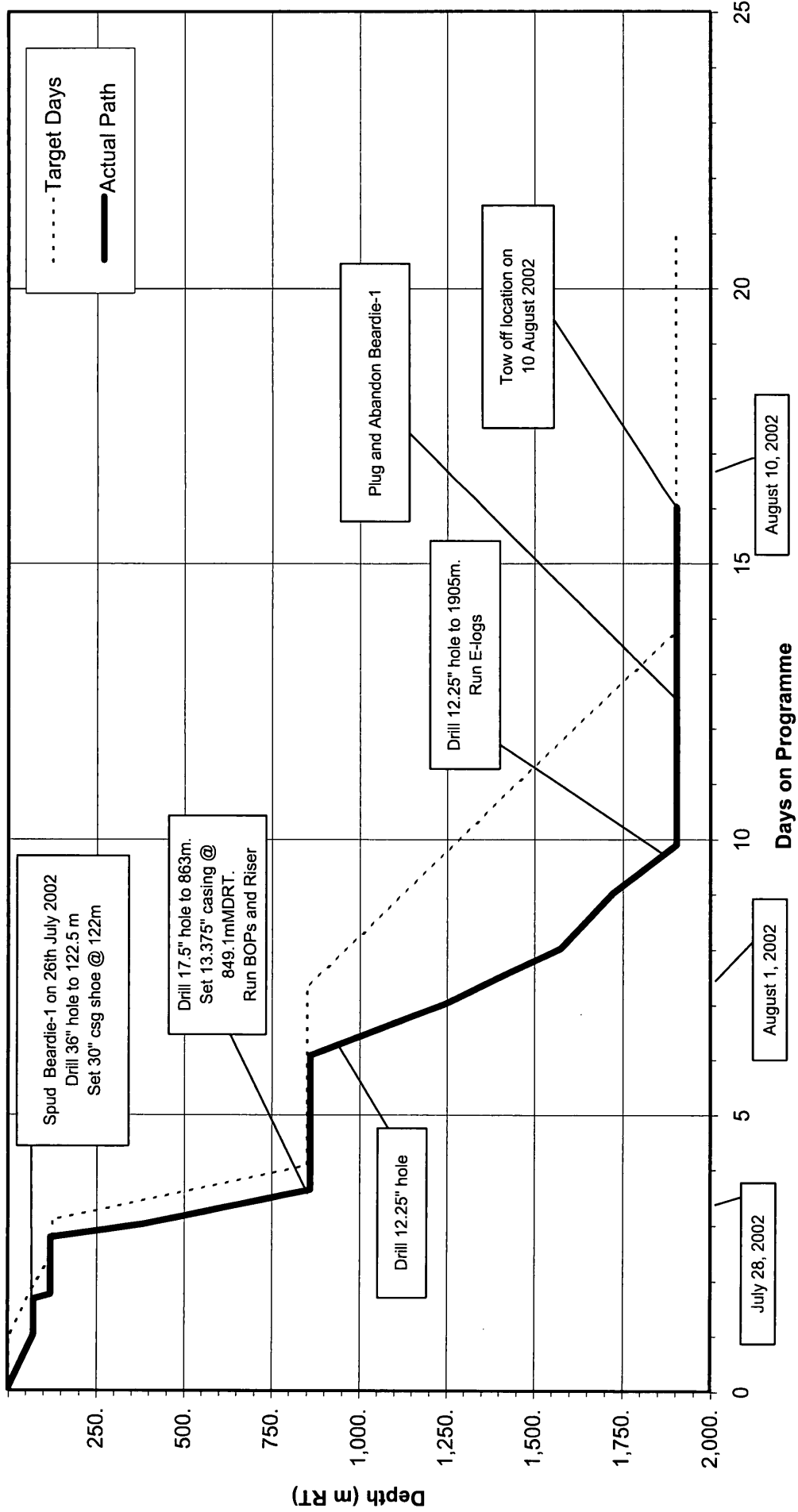

Appendices

APPENDIX 5

APPENDIX 5

VSP REPORT

VSP STACK SUMMARY LISTING

Gun and Hydrophone Coordinates:

Gun Azimuth		104.0	DEG
Gun Offset		61.0	M
Gun Depth	From Schlumberger Zero	30.5	M
Hydrophone Depth	From Schlumberger Zero	28.5	M
SRD Depth	From Schlumberger Zero	25.0	M

Other VSP constants:

True Vertical Time Correction	YES
Surface Velocity	1524.00 M/S

Stack number	Measured Depth (1) (M)	Measured Trans Time (MS)	True Vert. Depth from SRD (2) (M)	Corrected Trans Time (3) (MS)	Average Velocity (4) (M/S)
62	119.9	63.77	94.9	57.37	1697.17
62	135.0	68.23	110.0	63.66	1773.50
61	179.9	92.55	154.9	90.51	1743.63
61	195.0	96.44	170.0	95.26	1819.18
60	209.9	103.27	184.9	102.63	1834.76
60	225.0	110.81	200.0	110.59	1839.55
59	239.9	116.85	214.9	117.06	1866.44
59	255.0	123.19	230.0	123.75	1888.49
58	269.8	130.24	244.8	131.09	1896.11
58	284.9	137.26	259.9	138.36	1905.97
57	299.8	143.19	274.8	144.54	1928.37
57	314.9	150.19	289.9	151.74	1936.61
56	329.8	156.25	304.8	157.99	1954.92
56	345.0	162.18	320.0	164.11	1975.29
55	359.8	168.36	334.8	170.44	1989.20
55	375.0	174.57	350.0	176.79	2004.13
54	389.9	180.21	364.9	182.57	2022.82
54	405.0	186.20	380.0	188.68	2037.75
53	419.9	192.09	394.9	194.68	2051.87
53	435.0	197.94	410.0	200.63	2066.63
52	449.8	203.38	424.8	206.17	2083.34
52	465.0	208.91	440.0	211.79	2100.20
51	479.8	214.05	454.8	217.01	2118.34
51	494.9	219.37	469.9	222.41	2135.16
50	509.8	224.95	484.8	228.07	2147.82
50	525.0	230.24	500.0	233.41	2164.07
49	539.8	235.80	514.8	239.04	2175.31

49	555.0	241.30	530.0	244.60	2188.28
48	569.9	246.62	544.9	249.97	2201.11
48	585.0	252.09	560.0	255.49	2212.89
47	599.9	257.51	574.9	260.96	2223.81
47	615.0	262.83	590.0	266.32	2235.94
46	629.8	268.19	604.8	271.72	2246.18
46	644.9	273.36	619.9	276.94	2258.61
45	659.8	278.58	634.8	282.19	2269.55
45	675.0	283.60	650.0	287.25	2282.70
44	689.9	288.61	664.9	292.30	2294.47
44	705.0	293.76	680.0	297.48	2305.45
43	719.8	298.85	694.8	302.60	2315.55
43	735.0	303.96	710.0	307.74	2326.40
42	749.9	309.18	724.9	312.99	2335.14
42	765.0	314.22	740.0	318.06	2345.59
41	779.9	319.99	754.9	323.85	2349.67
41	795.0	325.67	770.0	329.56	2354.89
40	809.9	331.29	784.9	335.20	2359.79
40	825.0	337.55	800.0	341.48	2360.63
39	839.8	343.80	814.8	347.74	2360.68
39	855.0	350.01	830.0	353.97	2362.08
38	869.8	355.96	844.8	359.94	2364.05
38	885.0	361.74	860.0	365.74	2368.23
37	904.8	368.86	879.8	372.88	2376.06
37	920.0	374.21	895.0	378.25	2382.57
36	934.8	378.92	909.8	382.98	2391.96
36	949.9	383.53	924.9	387.61	2402.46
35	964.9	388.53	939.9	392.62	2410.09
35	980.0	393.31	955.0	397.42	2419.09
34	994.8	398.32	969.8	402.44	2425.77
34	1010.0	402.79	985.0	406.93	2436.48
33	1024.8	407.43	999.8	411.58	2445.02
33	1040.0	411.65	1015.0	415.82	2456.80
32	1054.9	415.91	1029.9	420.10	2467.36
32	1070.0	420.62	1045.0	424.82	2475.58
31	1084.9	425.41	1059.9	429.62	2482.71
31	1100.0	429.57	1075.0	433.79	2493.73
30	1114.8	433.39	1089.8	437.63	2505.85
30	1129.9	437.09	1104.9	441.34	2519.12
29	1139.8	440.00	1114.8	444.26	2524.92
29	1154.9	445.39	1129.9	449.66	2528.24
28	1169.9	451.24	1144.9	455.51	2528.65
28	1185.0	455.95	1160.0	460.24	2535.60
26	1199.9	462.10	1174.9	466.39	2534.04
26	1215.0	466.81	1190.0	471.11	2540.81
25	1229.8	471.95	1204.8	476.26	2544.43
25	1245.0	477.13	1220.0	481.45	2548.60
27	1259.8	482.18	1234.8	486.50	2552.62
27	1275.0	487.30	1250.0	491.64	2556.93
24	1291.9	493.18	1266.9	497.52	2560.67
24	1307.0	498.38	1282.0	502.73	2564.23
23	1324.9	504.79	1299.9	509.16	2567.05

23	1340.0	509.96	1315.0	514.33	2570.64
22	1354.9	516.18	1329.9	520.55	2568.50
22	1370.0	522.50	1345.0	526.88	2566.29
21	1384.8	528.60	1359.8	532.99	2564.63
21	1399.9	534.84	1374.9	539.23	2562.93
20	1414.9	540.46	1389.9	544.86	2564.00
20	1430.0	545.63	1405.0	550.03	2567.37
19	1444.8	550.41	1419.8	554.82	2571.91
19	1460.0	555.24	1435.0	559.66	2576.89
18	1474.8	559.94	1449.8	564.37	2581.66
18	1490.0	564.80	1465.0	569.23	2586.34
17	1504.8	569.53	1479.8	573.97	2590.82
17	1520.0	574.53	1495.0	578.96	2594.74
16	1534.9	579.54	1509.9	583.98	2598.00
16	1550.0	584.35	1525.0	588.80	2602.42
15	1564.9	589.94	1539.9	594.40	2602.98
15	1580.0	594.50	1555.0	598.96	2608.41
14	1584.8	595.62	1559.8	600.08	2611.56
13	1596.9	600.07	1571.9	604.53	2612.35
14	1599.9	600.71	1574.9	605.18	2614.54
13	1612.0	604.55	1587.0	609.02	2617.95
12	1626.8	608.63	1601.8	613.11	2624.66
12	1642.0	613.54	1617.0	618.02	2628.45
11	1654.9	616.27	1629.9	620.76	2637.70
11	1670.0	623.37	1645.0	627.86	2631.88
10	1684.9	629.18	1659.9	633.67	2631.25
10	1700.0	633.47	1675.0	637.97	2637.22
9	1712.8	639.98	1687.8	644.48	2630.41
9	1728.0	644.99	1703.0	649.49	2633.51
8	1741.8	649.18	1716.8	653.69	2637.77
8	1757.0	653.79	1732.0	658.30	2642.40
7	1771.8	658.63	1746.8	663.15	2645.43
7	1787.0	663.56	1762.0	668.08	2648.68
6	1799.8	668.16	1774.8	672.68	2649.61
6	1814.9	672.18	1789.9	676.71	2656.18
5	1824.8	675.64	1799.8	680.17	2657.22
5	1839.9	679.78	1814.9	684.31	2663.25
4	1854.8	684.63	1829.8	689.17	2666.12
4	1870.0	688.99	1845.0	693.53	2671.31
3	1884.8	693.69	1859.8	698.24	2674.53
3	1900.0	697.74	1875.0	702.29	2680.78

(1) Measured Depth is Cable Depth Referenced to Schlumberger Zero.

(2) TVD is referenced to SRD (5)

(3) Transit time with respect to SRD(5) corrected for Deviation.

(4) Average Velocity from close to source sensor to geophone.

(5) SRD is Seismic Reference Depth.

APPENDIX 6

PETROGRAPHY REPORT

913713 096



PETROLEUM SERVICES

PETROGRAPHIC REPORT

FOR

**ESSO AUSTRALIA PTY LTD
BEARDIE-1 WELL
GIPPSLAND BASIN
OFFSHORE AUSTRALIA**

File 020917G
December 2002

Performed by:
Core Laboratories, Advanced Technology Center
Reservoir Geology Group
6316 Windfern
Houston, Texas 77040
U.S.A.



Petroleum Services
6316 Windfern
Houston, Texas 77040 USA
Tel: 713-328-2673
Fax: 713-328-2170
www.corelab.com

December 5, 2002

Dr. John G. McPherson
Esso Australia Pty Ltd
12 Riverside Quay, Southbank 3006
Melbourne, Victoria 3001

Dear Dr. McPherson:

Core Laboratories in Houston, Texas, received from your company two (2) percussion sidewall core samples for detailed thin section petrography (includes a 250 point-count) and X-ray diffraction (XRD) analysis. The samples are from 1204 and 1212 meters in the Beardie-1 Well, Gippsland Basin, offshore Australia. The XRD data are provided in Table 1, and Table 2 shows the point-count results. Plates 1 and 2 show the thin section photomicrographs and descriptions. The following paragraphs summarize the results.

Texture: The sample from 1204 m is poorly sorted conglomeratic sandstone with an average grain size of 1.11 mm (very coarse sand), whereas the sample from 1212 m is moderately sorted, fine/very fine-grained carbonaceous/argillaceous sandstone with an average grain size of 0.13 mm. Both sandstones contain bioturbated clay matrix and organic (carbonaceous) debris, but these materials are common only in the fine/very fine-grained sandstone. Percussion sidewall sampling has partially altered the texture of these rocks.

Framework Grain Composition: The conglomeratic sandstone (1204 m) is classified as sublitharenite, according to Folk, et al. (1970). Plutonic rock fragments (4.8% by point-count) and K-feldspar (2.0% by point-count) are the only important grains besides the abundant quartz. The plutonic grains are largely quartz with small amounts of muscovite and/or K-feldspar. The fine-grained sample from 1212 m contains common amounts of K-feldspar and classifies as K-feldsarenite, but borderline subfeldsarenite. XRD results indicate the K-feldspar is maximum microcline (highly ordered). Carbonized organic debris is fairly common in the fine-grained sandstone. Mica grains are significant (4.8%) in the fine-grained sandstone, but rare in the conglomeratic sandstone. All other grain types occur in very minor to trace quantities.

Detrital Matrix: The detrital matrix in these sandstones consists of clay and silt-size micas mixed with some quartz and K-feldspar silt. XRD results show the clay fractions are dominated by kaolinite and lesser amounts of illite/mica. The kaolinite is concentrated in the matrix, probably from degradation of the illite/mica.

Authigenic Minerals: The principal authigenic material is iron sulfide. XRD results show both marcasite and pyrite in the sample from 1204 m and only pyrite in the deeper sample. These two iron sulfide minerals are not distinguished in the point-count results. The pyrite/marcasite mostly replaces carbonaceous debris and matrix. Point-count and XRD totals for pyrite/marcasite do not match favorably due to the highly irregular distribution of matrix and carbonaceous material. Small amounts of incipient quartz and

K-feldspar overgrowths appear to be present in the sample from 1212 m, but grain angularity and the presence of some relict quartz overgrowths make this determination difficult. Discrete pore-filling and mica-replacing kaolinite and grain-coating illite are rarely noted.

Porosity and Reservoir Quality: Percussion coring has partially altered the pore systems in these rocks, especially in the sample from 1204 m (Plate 1). The porosity comprises mostly intergranular pores: 7.6% in the sample from 1204 m and 4.0% in the sample from 1212 m. The intergranular pores are presumed to be effective for the flow of oil. These pores are much larger and more common in the conglomeratic sandstone (1204 m), where reservoir quality is predicted to be good for oil, especially if porosity has been undercounted due to percussion coring damage. Reservoir quality is predicted to be poor to fair for oil and fair to good for gas in the finer grained, argillaceous sandstone (1212 m).

Thank you for selecting Core Laboratories to perform these analyses for Esso Australia Pty Ltd. If you have any questions, or we can be of further service, please call.

Sincerely,



Drew Dickert
Senior Geologist
Core Laboratories
(713) 328-2574

File: 020917G

Table 1
Mineralogy Determined by X-ray Diffraction

Esso Australia Pty. Ltd.
Beardie-1 Well

Depth (m)	Whole Rock Mineralogy (Weight %)						Relative Clay Abundance (Normalized to 100%)			
	Quartz	K-Feldspar	Pyrite	Marcasite	Total Clay	Illite & Mica	Kaolinite	Chlorite	% Barite Removed	% Sylvite Removed
1204	89	1	2	5	3	21	79	0	2	Tr
1212	63	9	3	0	25	33	60	7	1	1

Note - Sylvite and Barite were removed as probable drilling contaminants
Tr = Trace

ORE LABORATORIES

Point-Count Tally Sheet

Company: Esso Australia Limited
 Well: Beardie-1
 Field: Gippsland Basin
 Location: Offshore Australia

C.L. File No: 020917G
 Date: 20-Nov-02
 Petrologist: D. Dickert

Table 2
 Modal Percent

Sample Depth (meters)		1204	1212
Quartz:	Monocrystalline	60.0	38.8
	Polycrystalline	14.0	4.0
	Total	74.0	42.8
Feldspars:	K-Feldspar	2.0	11.6
	Plagioclase		
	Undifferentiated Feldspar		
	Total	2.0	11.6
Rock Fragments:	Plutonic	4.4	1.2
	Volcanic	0.4	
	Siltstone/Sandstone		0.4
	Argillaceous		0.4
	Chert/Chalcedony		
	Metamorphic	0.4	1.6
	Total	5.2	3.6
Accessory:	Biotite		1.2
	Muscovite		3.2
	Chlorite		0.4
	Tourmaline		0.4
	Carbonaceous Debris	1.6	8.8
	Glauconite		
	Foraminifer Tests		
	Other Fossils		
	Total	1.6	14.0
Matrix:	Detrital Clay (micaceous)	3.6	8.4
	Pseudomatrix		
	Total	3.6	8.4
Clays: (Authigenic)	Kaolinite		
	Chlorite		
	Sericite		
	Undifferentiated Clay		
	Total		
Non-Clay Cements:	Quartz Overgrowths		1.2
	Feldspar Overgrowths		0.8
	Fe-Calcite		
	Fe-Dolomite		
	Barite		
	Siderite		
	Pyrite/Marcasite	3.6	12.0
	Titanium oxides		1.2
	Analcime		
Total	3.6	15.2	
Porosity:	Intergranular	7.6	4.0
	Intragranular		
	Grain-moldic	0.8	
	Grain Fractures	1.6	
	Open Fractures		0.4
	Total	10.0	4.4
Grand Total	100.0	100.0	

Company: Esso Australia Pty Ltd
 Well: Beardie-1
 Location: Offshore Australia
 Depth (m): 1204

Helium Porosity (%): N.A.
 Permeability (md): N.A.
 Grain Density (g/cc): N.A.
 Rock Type: Conglom. Sandstone

Rock Name and Texture

Name (Folk, 1970) Sublitharenite
 Grain Size (mm) <0.03-5.1 (av. = 1.11)
 Grain Sorting Poor
 Roundness Angular to well rounded
 Compaction Moderate?
 Structures Probably bioturbated

Image A

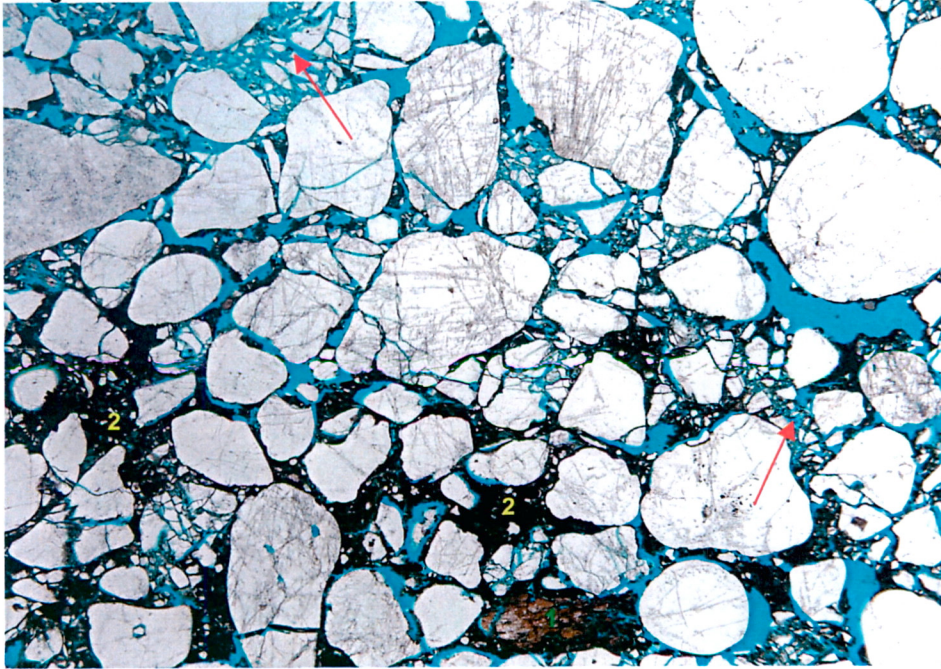

Rock Composition (point-count %)

Framework Grains		Matrix:	3.6
Quartz:	74.0	Detrital Clay	3.6
Quartz (mono)	60.0	Pseudomatrix	
Quartz (poly)	14.0	Cement:	3.6
Feldspars:	2.0	Chlorite	
K-feldspar	2.0	Kaolinite	
Plagioclase		Sericite	
Rock Fragments:	5.2	Undiff. I/S	
Igneous	4.8	Quartz O.G.	
Limestone		Felds. O.G.	
Argillaceous		Calcite	
Silt/Sandstone		Fe-Dolomite	
Chert/Chalced.		Siderite	
Metamorphic	0.4	Pyrite/Marc.	3.6
Accessories:	1.6	Ti Oxide	
Mica		Zeolites	
Heavy Minerals		Porosity:	10.0
Carbonaceous	1.6	Intergranular	7.6
Other Fossils		Intragranular	
Glauconite		Moldic	0.8
Chlorite		Microporosity	
Organic Debris		Fractures	1.6

Image B

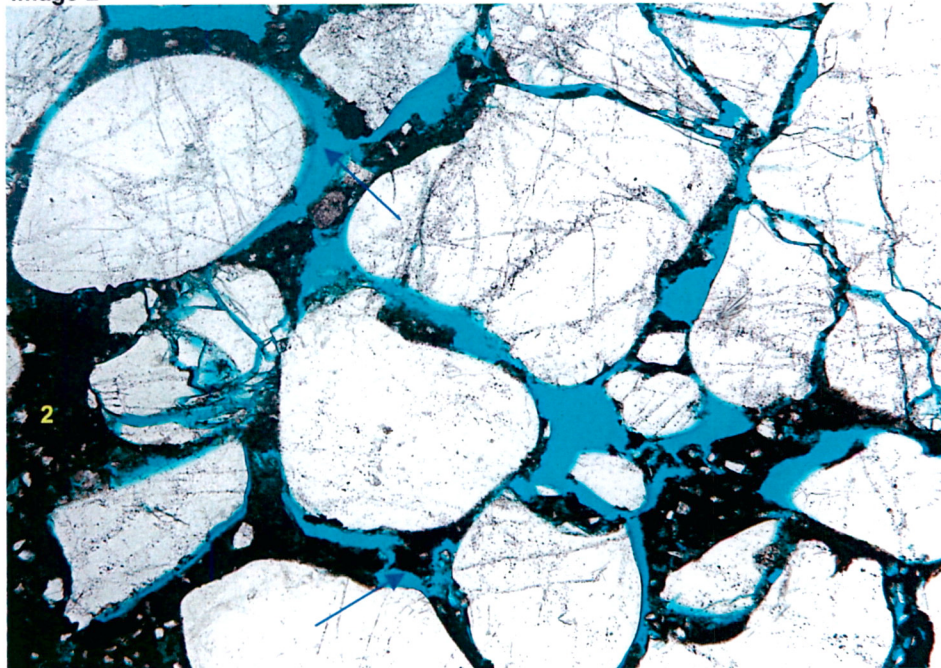

Petrographic Description

Framework grains are predominantly quartz (white) in this poorly sorted, conglomeratic sandstone. Small amounts of K-feldspar (stained yellow; 1) are also present. Minor amounts of silty clay matrix (2) are irregularly distributed, probably from bioturbation. The matrix contains numerous marcasite and pyrite crystals that impart a black color. The texture of this rock has been altered by percussion coring; shattered grains (red arrows) are sometimes difficult to distinguish from natural grains. Also, the intergranular pore system (blue) has been collapsed in some areas and expanded (blue arrows) in other areas. Reservoir quality appears to be good for oil.



Trace (<1%)
 Minor (1-5%)
 Moderate (5-10%)
 Common (10-20%)
 Abundant (>20%)

Company: Esso Australia Pty Ltd
 Well: Beardie-1
 Location: Offshore Australia
 Depth (m): 1212

Helium Porosity (%): N.A.
 Permeability (md): N.A.
 Grain Density (g/cc): N.A.
 Rock Type: Carbon./Argillaceous Sandstone

Rock Name and Texture

Name (Folk, 1970) K-feldsarenite
 Grain Size (mm) <0.02-0.49 (av. = 0.13)
 Grain Sorting Moderate
 Roundness Angular to subrounded
 Compaction Moderate to heavy
 Structures Carbonaceous/argillaceous laminae, bioturbated

Rock Composition (point-count %)

Framework Grains		Matrix:	
Quartz:	42.8	Detrital Clay	8.4
Quartz (mono)	38.8	Pseudomatrix	
Quartz (poly)	4.0	Cement:	15.2
Feldspars:	11.6	Chlorite	
K-feldspar	11.6	Kaolinite	
Plagioclase		Sericite	
Rock Fragments:	3.6	Undiff. I/S	
Igneous	1.2	Quartz O.G.	1.2
Limestone		Felds. O.G.	0.8
Argillaceous	0.4	Calcite	
Silt/Sandstone	0.4	Fe-Dolomite	
Chert/Chalced.		Siderite	
Metamorphic	1.6	Pyrite/Marc.	12.0
Accessories:	14.0	Ti Oxide	
Mica	4.4	Zeolites	
Heavy Minerals	0.4	Porosity:	4.4
Carbonaceous	8.8	Intergranular	4.0
Other Fossils		Intragranular	
Glauconite		Moldic	
Chlorite	0.4	Microporosity	
Organic Debris		Fractures	0.4

Image A

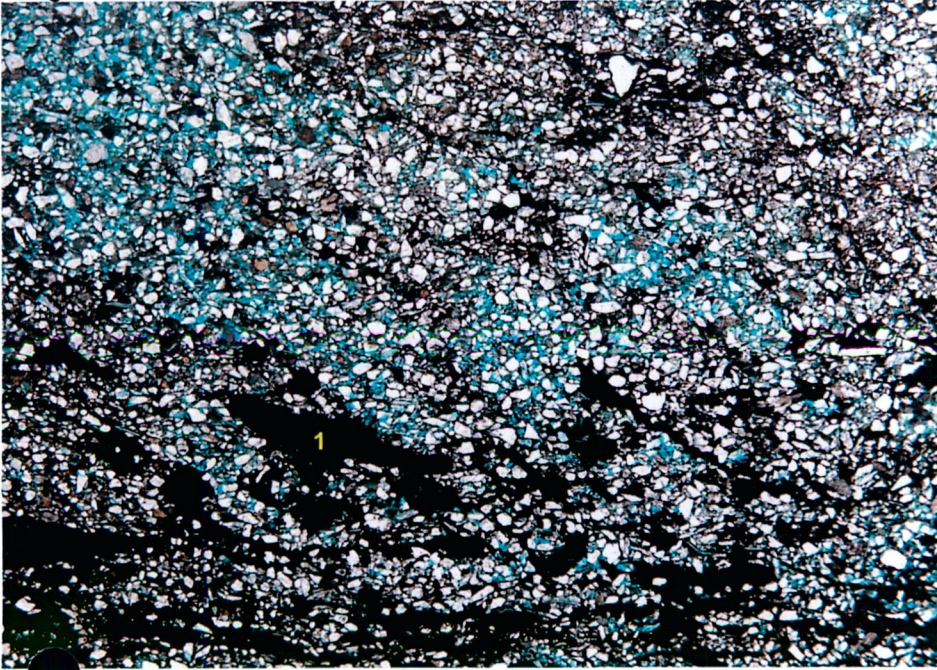
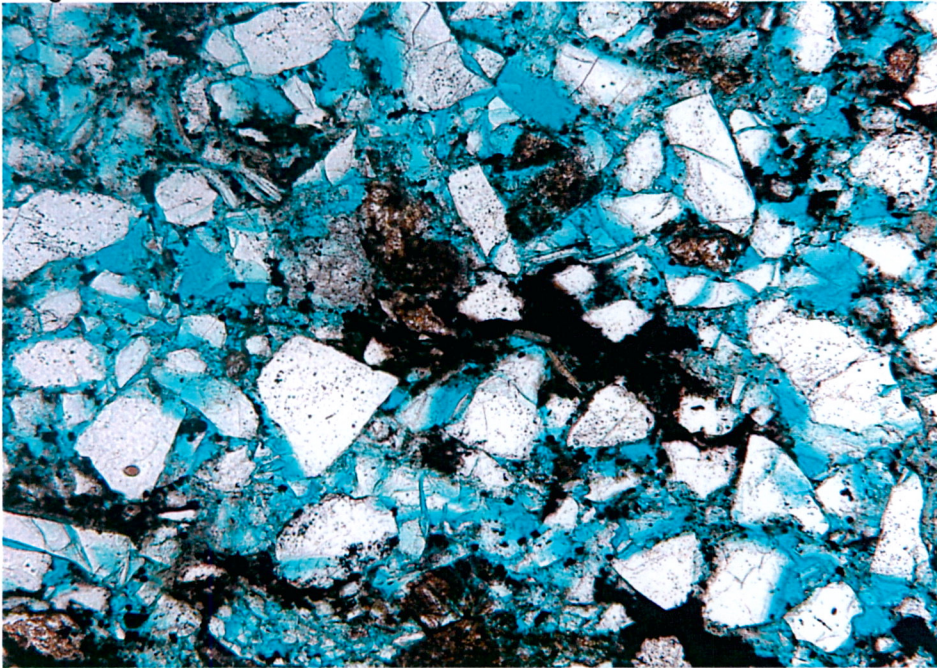

Image B



Petrographic Description

Laminae containing large amounts of detrital clay matrix (brown) and carbonized plant debris (black) have been disrupted by bioturbation. The carbonaceous material is highly pyritized (1). Quartz (white) is the principal framework grain, but K-feldspar (stained yellow) is also fairly common. Intergranular pores (blue) are common in a few of the laminae and burrows. Reservoir quality is predicted to be poor to fair for oil and fair to good for gas.



Trace (<1%)
 Minor (1-5%)
 Moderate (5-10%)
 Common (10-20%)
 Abundant (>20%)

913713 103

Enclosures

ENCLOSURES

913713 104

ENCLOSURE 1

MUD LOG

913713 105

Formation Evaluation Log

1: 500

PE651032

This is an enclosure indicator page.
The enclosure PE651032 is enclosed within the
container PE913713 at this location in this
document.

The enclosure PE651032 has the following characteristics:

ITEM_BARCODE = PE651032
CONTAINER_BARCODE = PE913713
NAME = Beardie-1 Mud Log, Scale 1:500
BASIN = GIPPSLAND
ONSHORE? = N
DATA_TYPE = WELL
DATA_SUB_TYPE = MUD_LOG
DESCRIPTION = Beardie-1 Formation Evaluation Log/ Mud
Log, Scale 1:500, (Encl. 1 from
Beardie-1 Well Completion Report, Vol.
1, Basic Data), Gippsland Basin,
Victoria, Baker Hughes Inteq, Esso
Australia Pty. Ltd., August 2002.
REMARKS =
DATE_WRITTEN = 03-AUG-2002
DATE_PROCESSED =
DATE_RECEIVED =
RECEIVED_FROM = Esso Australia Pty Ltd
WELL_NAME = Beardie-1
CONTRACTOR = Esso Australia Pty Ltd
AUTHOR =
ORIGINATOR = Esso Australia Pty Ltd
TOP_DEPTH = 76.2
BOTTOM_DEPTH = 1905
ROW_CREATED_BY = FH11_SW

(Inserted by DNRE - Vic Govt Mines Dept)

913713 107

ENCLOSURE 2

PRESSURE LOG

913713 108

Pressure Data Plot

1: 1000

PE651033

This is an enclosure indicator page.
The enclosure PE651033 is enclosed within the
container PE913713 at this location in this
document.

The enclosure PE651033 has the following characteristics:

- ITEM_BARCODE = PE651033
- CONTAINER_BARCODE = PE913713
 - NAME = Pressure Data Plot, Scale 1:1000
 - BASIN = GIPPSLAND
 - ONSHORE? = N
 - DATA_TYPE = WELL
 - DATA_SUB_TYPE = WELL_LOG
 - DESCRIPTION = Beardie-1 Pressure Data Plot, Scale
1:1000, (Encl. 2 from Beardie-1 Well
Completion Report, Vol. 1, Basic Data),
Gippsland Basin, Victoria, Baker Hughes
Inteq, Esso Australia Pty. Ltd.
- REMARKS =
- DATE_WRITTEN =
- DATE_PROCESSED =
- DATE_RECEIVED =
- RECEIVED_FROM = Esso Australia Pty Ltd
- WELL_NAME = Beardie-1
- CONTRACTOR = Esso Australia Pty Ltd
- AUTHOR =
- ORIGINATOR = Esso Australia Pty Ltd
- TOP_DEPTH = 70
- BOTTOM_DEPTH = 1904.89
- ROW_CREATED_BY = FH11_SW

(Inserted by DNRE - Vic Govt Mines Dept)

Pressure Summary Plot

Pressure Summary Plot Beardie - 1

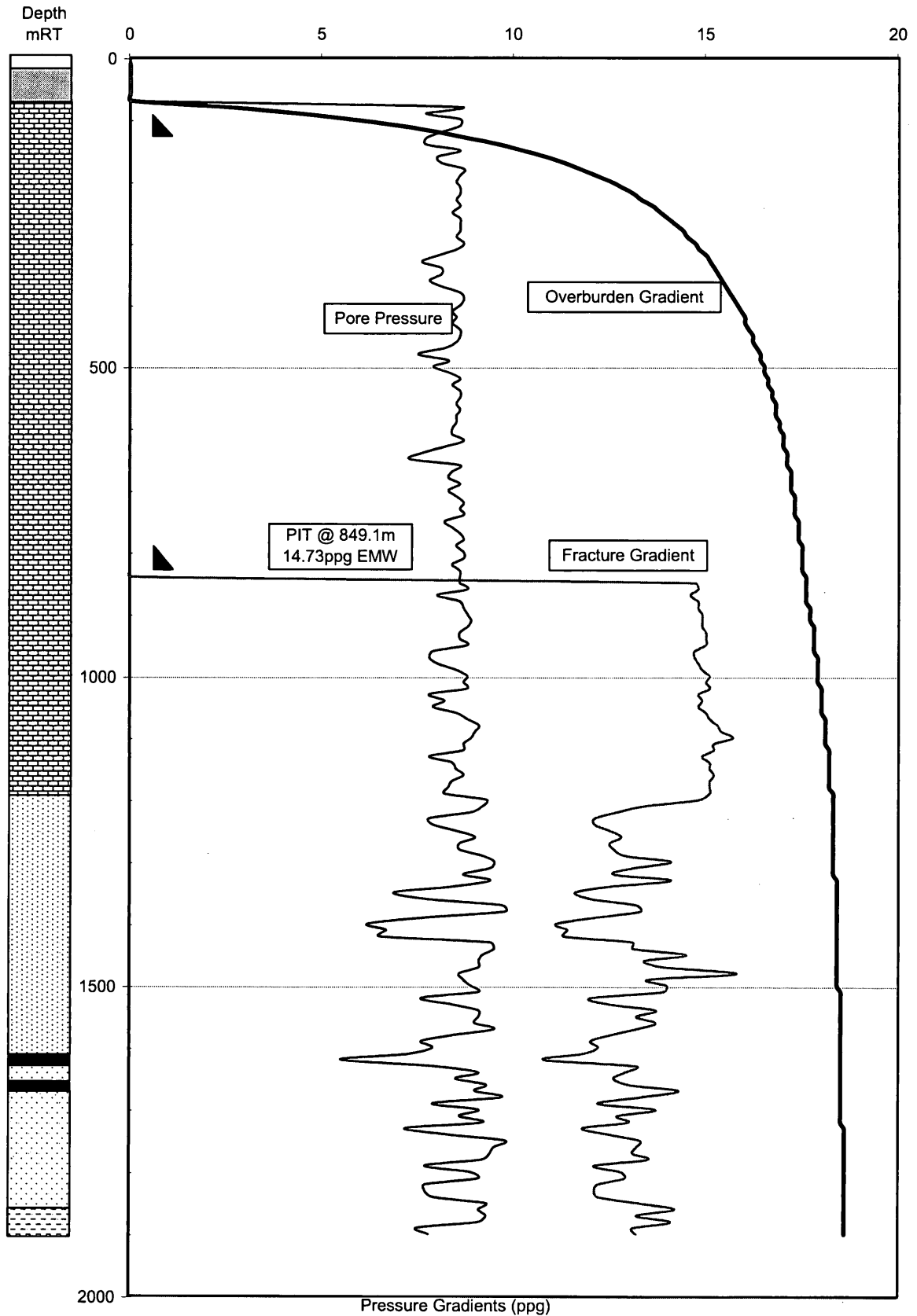

913713 112

ENCLOSURE 3

DRILLING LOG

913713 113

Drilling Data Plot
1: 1000

PE651034

This is an enclosure indicator page.
The enclosure PE651034 is enclosed within the
container PE913713 at this location in this
document.

The enclosure PE651034 has the following characteristics:

ITEM_BARCODE = PE651034
CONTAINER_BARCODE = PE913713
 NAME = Drilling Data Plot, Scale 1:1000
 BASIN = GIPPSLAND
 ONSHORE? = N
 DATA_TYPE = WELL
 DATA_SUB_TYPE = WELL_LOG
 DESCRIPTION = Beardie-1 Drilling Data Plot, Scale
 1:1000, (Encl. 3 from Beardie-1 Well
 Completion Report, Vol. 1, Basic Data),
 Gippsland Basin, Victoria, Baker Hughes
 Inteq, Esso Australia Pty. Ltd.
 REMARKS =
 DATE WRITTEN =
 DATE PROCESSED =
 DATE RECEIVED =
 RECEIVED_FROM = Esso Australia Pty Ltd
 WELL_NAME = Beardie-1
 CONTRACTOR = Esso Australia Pty Ltd
 AUTHOR =
 ORIGINATOR = Esso Australia Pty Ltd
 TOP_DEPTH = 76
 BOTTOM_DEPTH = 1905
 ROW_CREATED_BY = FH11_SW

(Inserted by DNRE - Vic Govt Mines Dept)

ENCLOSURE 4

GAS RATIO LOG

913713 116

Gas Ratio Analysis Plot

1: 500

PE651035

This is an enclosure indicator page.
The enclosure PE651035 is enclosed within the
container PE913713 at this location in this
document.

The enclosure PE651035 has the following characteristics:

ITEM_BARCODE = PE651035
CONTAINER_BARCODE = PE913713
NAME = Gas Ratio Analysis Plot, Scale 1:500
BASIN = GIPPSLAND
ONSHORE? = N
DATA_TYPE = WELL
DATA_SUB_TYPE = WELL_LOG
DESCRIPTION = Beardie-1 Gas Ratio Analysis Plot,
Scale 1:500, (Encl. 4 from Beardie-1
Well Completion Report, Vol. 1, Basic
Data), Gippsland Basin, Victoria, Baker
Hughes Inteq, Esso Australia Pty. Ltd.
REMARKS =
DATE_WRITTEN =
DATE_PROCESSED =
DATE_RECEIVED =
RECEIVED_FROM = Esso Australia Pty Ltd
WELL_NAME = Beardie-1
CONTRACTOR = Esso Australia Pty Ltd
AUTHOR =
ORIGINATOR = Esso Australia Pty Ltd
TOP_DEPTH = 70
BOTTOM_DEPTH = 1905
ROW_CREATED_BY = FH11_SW

(Inserted by DNRE - Vic Govt Mines Dept)